

# Miniball electronics at May 2009

## Contents

|  |    |
|--|----|
| 1 Foreword   | 3  |
| 2 Notation   | 4  |
| 3 The CD cabling                                     | 4  |
| 4 The delayed CD quadrant signal                     | 5  |
| 5 Generation of the gamma gate                       | 6  |
| 6 Generation of triggers                             | 6  |
| 7 Generation of the DAQ dead signals                 | 7  |
| 8 Generation of the DAQ trigger                      | 7  |
| 9 Generation of the ADC gates and the TDC stops      | 8  |
| 10 Generation of the EBIS window                     | 8  |
| 11 Generation of the off window                      | 9  |
| 11.1 Multiple off-window mode . . . . .              | 10 |
| 12 Generation of the on/off window                   | 11 |
| 13 The generation of the GFLT                        | 11 |
| 14 The DGF BUSY/SYNCH loop                           | 12 |
| 15 Changes for the Mesytech MAD32 modules            | 12 |
| 16 Note about special signals                        | 14 |
| 17 Generation of the T1 timestamp                    | 14 |
| 18 Generation of the proton supercycle timestamp     | 14 |
| 19 Generation of the control signals for the scalers | 16 |
| 19.1 Scalers in proton-triggered mode . . . . .      | 16 |
| 20 Generation of pattern unit control signal         | 17 |
| 21 Generation of the forced readout                  | 17 |
| 22 The pattern unit bits                             | 17 |
| 23 Laser on/off                                      | 18 |
| 24 1 MHz and EBIS, 1 MHz and GFLT                    | 18 |
| 25 The DAQ crash reset                               | 19 |
| 26 The Bragg chamber                                 | 19 |
| 27 The ionisation chamber                            | 20 |
| 28 DGF backplane bus                                 | 20 |
| 29 Scalers   | 21 |

---

<sup>1</sup>Nigel Warr 13 May 2009

|  |           |
|--|-----------|
| <b>30 Positions of modules in crates and racks</b>     | <b>21</b> |
| 30.1 Rack 1 . . . . .                                  | 21        |
| 30.1.1 CAMAC crate R1.C2 . . . . .                     | 21        |
| 30.1.2 NIM crate R1.C3 . . . . .                       | 22        |
| 30.1.3 NIM crate R1.C4 . . . . .                       | 22        |
| 30.2 Rack 2 . . . . .                                  | 23        |
| 30.2.1 KM-6 crate R2.C1 . . . . .                      | 23        |
| 30.2.2 KM-6 crate R2.C2 . . . . .                      | 24        |
| 30.2.3 New DAQ computer and raid array R2.C3 . . . . . | 25        |
| 30.2.4 CD connectors and power supplies . . . . .      | 25        |
| 30.3 Rack 3 . . . . .                                  | 25        |
| 30.3.1 VME crate R3.C1 . . . . .                       | 25        |
| 30.3.2 NIM crate R3.C2 . . . . .                       | 26        |
| 30.3.3 NIM crate R3.C3 . . . . .                       | 27        |
| 30.3.4 NIM crate R3.C4 . . . . .                       | 28        |
| 30.3.5 Preamp power - R3 rear . . . . .                | 29        |
| 30.4 Rack 4 . . . . .                                  | 30        |
| 30.4.1 CAMAC crate R4.C1 . . . . .                     | 30        |
| 30.4.2 CAMAC crate R4.C2 . . . . .                     | 31        |
| 30.4.3 R4.C3 . . . . .                                 | 32        |
| 30.4.4 NIM crate R4.C4 . . . . .                       | 34        |
| 30.5 Rack 5 . . . . .                                  | 34        |
| 30.5.1 Autofill connections - R5 rear . . . . .        | 35        |
| 30.5.2 HV connections - R5 rear . . . . .              | 35        |

# 1 Foreword

This document describes the state of the electronics used at CERN for the May 2009 setup. It is based on the one for It is based on the one for May 2008, which was based on the one for June 2007, which was based on the one for May 2006, which was based on May 2005, which in turn was based on the one for July 2004.

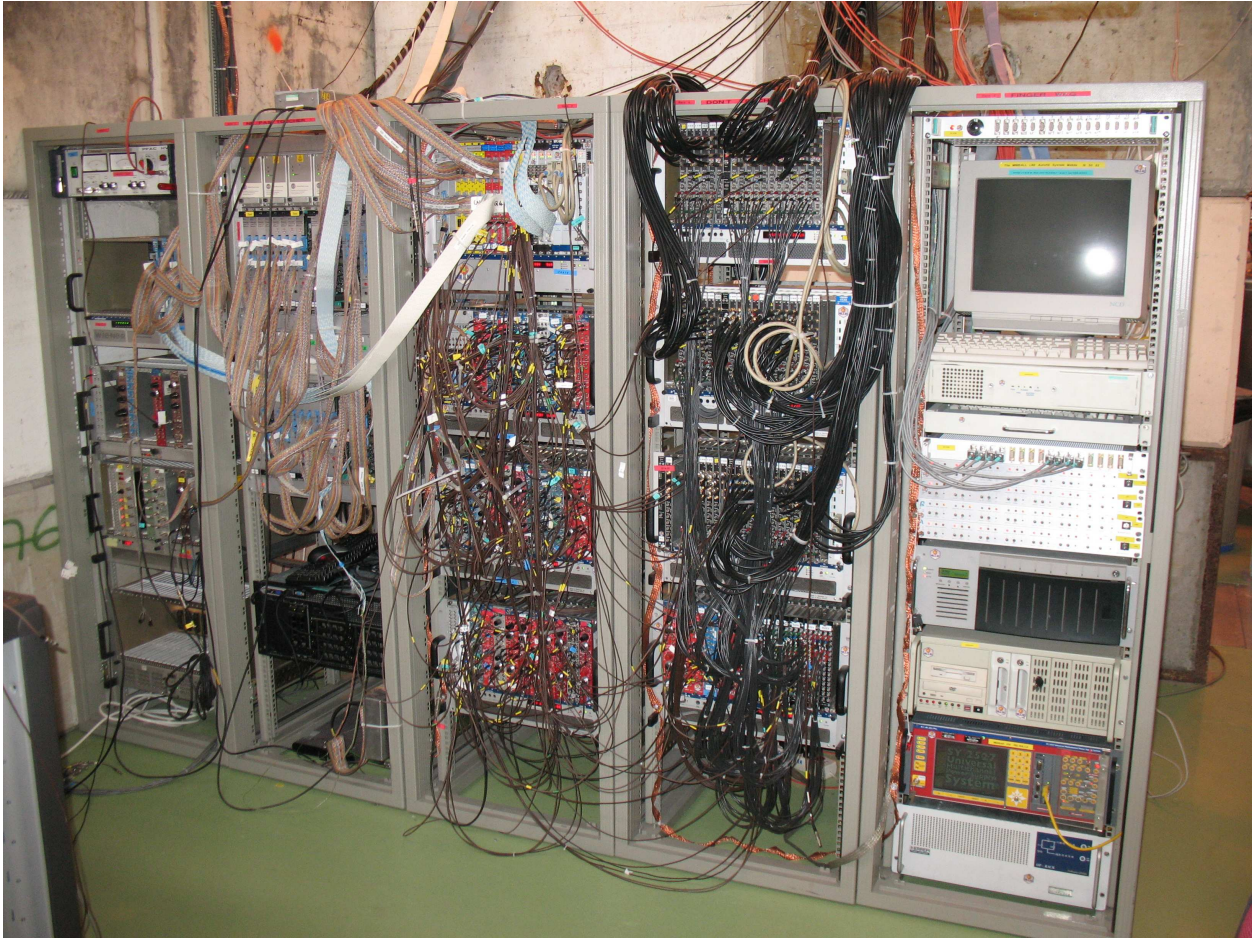

Figure 1: The Miniball electronics in 2009.

The differences to 2004 to 2005 have been indicated, notably the addition of laser on/off bits in the pattern unit and the Munich ionisation chamber, and changes in the TDC cabling. That means it is different to all previous experiments and is likely to be different to future ones. However, there should be certain similarities.

The electronics for this setup has grown gradually rather than being thought out as a single setup, so modules were not necessarily placed in the optimal position in the crates. In places, signals were duplicated due to different people building different parts of the setup and not realizing that the signal they were constructing was already available elsewhere.

In November 2004, a part of the electronics was dismantled and sent to GSI, Darmstadt, and the racks were all moved in order to allow for the building work to extend the ISOLDE hall. However, care was taken then to label things, so that they could be put back together. In May 2005, we put the things back together and it is believed that the state of November 2004 was achieved. In doing so, we noticed some changes with respect to the July 2004 setup. These all seem to be deliberate improvements.

However, the setup works, so there is no reason to change it for this campaign, but it could be improved on in the future.

Caveat: this document was produced during the setup with all the interruptions that that entails, so it probably contains mistakes. Several mistakes have already been found and corrected. There are likely to be others! Also people were still modifying the electronics while I was noting down the configuration. Use it with caution!

The main difference between the 2003 and 2004 setups is that in 2003 all of the CD was treated as one unit, whereas in 2004, each quadrant was dealt with separately. Also, in 2004 we took the ADC busy directly from the ADC module, whereas in 2003 we generated our own signal which was longer than the one generated by the module. Back then, we thought (erroneously) that the ADC was giving a busy signal which was too short and was the reason for mismatches in the number of ADC gates and the number of timestamp DGF events. In fact, the problem turned out to be due to the DGF sometimes missing the last event, so there was no reason to artificially generate the ADC busy.

Part way through 2005, a change was made to the way the TDCs were triggered. Before this change, a signal was generated from the particles and sent via an NIM to ECL converter to one of the last 16 channels of the TDC. After the modification, flat cables were taken from the MALUs giving the hit pattern in the front part of the CD, combined together in pairs (i.e. 8 signals from 16 rings). However, they weren't cabled very logically, so that for the ADCs had the front part of the CD on channels 0 to 15 and the back on 16 to 27 with 27 to 31 unused, but the TDCs had the back of the CD on channels 0 to 11, 12 to 15 unused and the front on 16 to 23. For 2006, we have adopted the same convention for the TDCs as for the ADCs, so the front is first and the back comes after. Consequently, we removed the NIM to ECL converter that was used for this.

In 2005, we also used the Miniball HV main frame to produce the high voltage for the beam dump detector. Prior to that we used a NIM power supply.

Another minor change in 2006: we moved the TDCs one slot to the left and put the ADC for the ionisation chamber to their right, rather than having the ionisation chamber ADC between the ADCs and TDCs for the CD. We also swapped a VME scaler with NIM inputs and the adjacent VME scaler for the PPAC.

In 2007, all the electronics was moved from the platform down to the new hall. However, very little was changed during this move. The main differences are in the electronics to the Bragg chamber. Also, the  $\Delta E$  detectors, which have not been used in the last few campaigns, but had been cabled in the electronics racks, were not put in the electronics this time.

At the end of 2007, an extra crate was put into rack 1, which was empty at the start of the 2008 campaign. This has the result of renumbering the bottom crate in that rack. Also an ECL  $\rightarrow$  NIM converter in that crate was moved from the first slot to the last, as some additional cables were added for the Munich setup, which were too short otherwise.

The last scaler (Bragg chamber) was modified in 2008. In 2007 it was added as an afterthought and it was not documented. It used a linear amplifier on the analogue signal going to the VME sampling ADC and sent this signal directly into the scaler. The additional amplification made it go above the threshold of the scaler, so it counted. However, this is an ugly way of doing things! In 2008, the logical output of the sampling ADC was used. However, as this signal is needed for the logic, it is only accessible after gating with the GFLT and the DAQ not dead signals. This shouldn't matter, as we don't expect particles in the Bragg chamber when there is no beam and we can't count them if the DAQ is dead.

The biggest change in 2008 is to the autofill system. This is especially complicated as it was desired to have both the old and the new systems available. The old system runs on pcepssc22 and the new on the old DAQ computer pcepui20. The old system uses ISA cards inside the DAQ computer with two flat cables which connect to manifolds B and D (a small flat cable connects A with B and C with D). The new system uses an external USB unit with two flat cables, which are pin-to-pin compatible with the old system and likewise go to manifolds B and D. The old system uses a custom-made PT100 box which is connected to the PC with a flat cable. The new system uses a different PT100 box, which is connected by two USB cables.

In May 2009 the CAEN V785 VME ADCs were replaced with Mesytech MAD32 modules. These modules are capable of timestamping the data with a 40 MHz clock like the DGFs, so it should be possible in future to do away with the timestamper DGFs. However, for the 2009 campaign, we retain both possibilities. i.e. the gate sent to the Mesytech ADCs is sent to the signal input of a DGF to generate a timestamp. This should be approximately the same as the timestamp from the Mesytech's own clock. So this data is duplicated in the list mode. If the Mesytech data proves reliable, we can in future campaigns leave out the timestamper DGFs. Note, however, that the timestamper DGFs for the EBIS, T1 and PS signals have to remain. For convenience and to allow a fast switch back to the CAEN modules if the Mesytech modules don't work, the same VME addresses have been used for both, so it is just a matter of switching the modules and taking the Marabou configuration from 2008.

## 2 Notation

I have used the notation "R2.C4.S13" to mean rack two (starting at 1 nearest the wall) crate four (starting with 1 at the top), slot 13. Similarly "R2.C4" means all of crate four of rack two. In the diagrams, the location of the modules is indicated in magenta.

## 3 The CD cabling

There are two crates of RAL109 shaping amplifier modules. The top one (R2.C1) is for the 16 front rings and the bottom one (R2.C2) is for the 24 back sectors.

The analogue outputs of the RAL109s for the front go directly to channels 0 to 15 of the Mesytech MAD32 VME ADCs in R3.C1.4-7 (i.e. the lower part of the ADCs).

The analogue outputs of the RAL109s for the back also go directly to channels 16-31 of the same ADCs, but since we only use 12 signals (we combine the 24 sectors per quadrant of the back of the CD into 12

signals, by connecting them pairwise - this is done in the hardware) there are some channels spare. By picking off a couple of the wires from these cables, the CD PAD detector (another RAL109 in R2.C1) and the laser power (from the laser control box) are also put into the ADCs.

The ECL outputs of the RAL109s for the front are connected into the four MALU modules (R1.C2.S17,19,21, 23). From there, the ORO signals are connected via a flat cable, where the ends have been split at the MALU end, to an ECL to NIM converter (R1.C4.S23). Also, flat cables connect the outputs of the MALUs to the CAEN V775 32-channel TDCs in R3.C1.8-11 (channels 0 to 15, i.e. the lower part).

For the back sectors, the ECL outputs are connected directly to the same TDCs on channels 16-31 (i.e. the upper part).

Additionally channels 0 and 1 of the laser box are connected to channels 28 and 29 of the quadrant 1 ADC (R3.C1.S4). It looks like the latter one is the laser power.

The signals from the PAD detector come from a different RAL109 in R2.C1 and should each be connected to channel 30 of the ADCs (R3.C1.S4-7). This is done by splitting off two channels from the flat cable and connecting them individually. However, because of the modification to the cable for quadrant 1 in order to add in the laser power (actually, a new cable was made - it is blue and white, while the others are multicoloured), it looks as though quadrant 1 of the PAD detector isn't connected any more.

Probably, we should make a new cable for quadrant 1, with both the PAD and the laser power.

## 4 The delayed CD quadrant signal

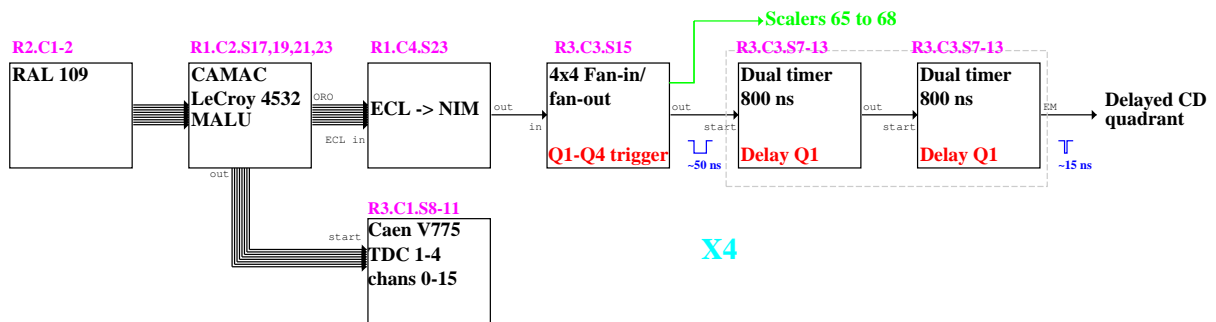

Figure 2: The generation of the delayed CD quadrant signal. This is done for each of the four quadrants of the CD.

From the CD we need to generate logic signals to indicate when an event has occurred in a given quadrant. Note that in previous setups we treated the whole CD as one, but now we treat it as four independent quadrants.

For each quadrant, we take the logic output from the RAL 109 shaper amplifiers via a flat cable to four CAMAC MALU units. Note that although these are CAMAC modules, we do not need to program them, so they are in a crate without a CAMAC crate controller. They just take their power from the CAMAC crate.

Each MALU gives a differential ECL *ORO* output (this is just an OR of all the inputs) and these signals for all four MALUs are combined on a single flat cable and sent to an ECL  $\rightarrow$  NIM converter. From there, the signal for each quadrant goes into one quarter of a 4x4 fan-in/fan-out module and then is used to start a dual timer.

We use two copies of the signal from this fan-out.

- One goes to a scaler. We use scaler 65 for quadrant 1, scaler 66 for quadrant 2 etc.
- One copy is delayed by 800 ns to generate the delayed CD quadrant signal.

We want to delay this signal by 800 ns, but the CAEN dual timers have the property that if a second signal arrives during that time, the end marker comes 800 ns after the **second** signal, not the first. So we use half of a dual timer to generate a signal which is 800 ns wide and then use that to start the second half of the same module also set to 800 ns (so both start more or less simultaneously, but the delaying of the end marker is suppressed). We then take the end marker from the second half of the module. There are probably better ways to do this. In all probability this behaviour of the dual gate is a feature but it doesn't seem to be possible to turn it off and the manual is utterly useless. Perhaps a different kind of gate generator would be better, or a discriminator followed by a gate generator. In future years we should really rethink this part.

For all four quadrants, we use four MALUs, one ECL  $\rightarrow$  NIM converter, one fan-in/fan-out module and four dual timers.

Note that the RAL109s and the NIM crate containing the NIM  $\rightarrow$  ECL converter are in the CD electronics rack, and the CAMAC crate with the MALUs are in the leftmost rack.

Previously, we took a third copy of the signal from the fan-out, passed it through a NIM to ECL converter and used it to start a TDC channel for each quadrant. Some time in 2005 this was changed and now, we take an additional flat cable from each MALU to the corresponding TDC so we have a hit pattern rather than just the OR.

## 5 Generation of the gamma gate

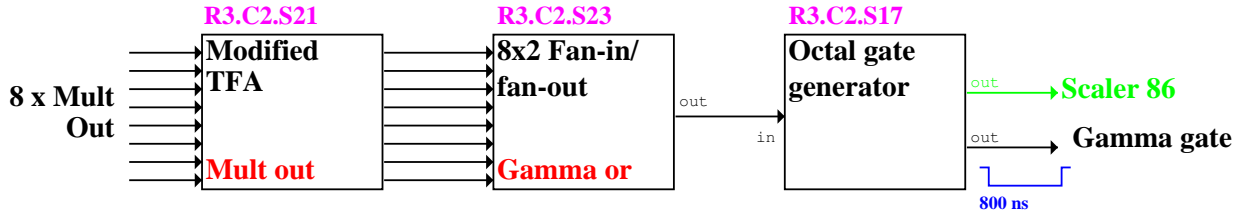

Figure 3: The generation of the gamma gate. This is the logical OR of all the signals from the Ge cores.

We need to generate a signal indicating that one of the Ge detectors has an event. To do this we take the Mult Out (35 mVolt per hit) from the DGF having the first core signal and put it into the Mult In of the next DGF with a core signal (i.e. the third DGF) and from its Mult Out to the DGF with the third core. We then send this signal (i.e. one for each of the eight clusters) to a specially modified TFA (which contains eight Ge preamplifiers set to saturate with a 35 millivolt signal and generate a -0.8 Volt NIM output). In other words, the special module simply converts the 35 mV per hit signal into NIM logic. This signal is passed into a fan-in/fan-out.

This signal is used to generate the particle-gamma coincidence. Note that its width is determined by the DGF parameter *FTPWIDTH*.

## 6 Generation of triggers

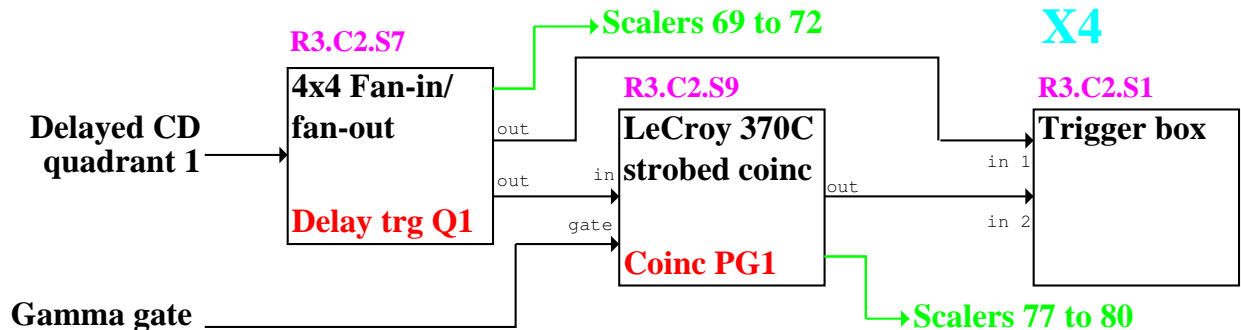

Figure 4: The generation of the triggers. The gamma gate is common to all four quadrants of the CD, but the rest is repeated for each quadrant with the second quadrant using channels 3 and 4 of the trigger box, the third using 5 and 6 and the last quadrant using the two remaining channels 7 and 8.

The delayed CD quadrant signal for each quadrant is passed to a fan-in/fan-out unit (a different quarter of the unit for each quadrant) and for each quadrant, we use three copies of this signal.

- One goes directly to the trigger box where it is downscaled (downscaled particles).
- The second goes into a strobed coinc unit and from there to the trigger box. The strobed coinc unit gates each input (one for each quadrant of the CD) with the gamma gate (see section 5). This gives the particle- $\gamma$  coincidence.
- The third copy goes to a scaler.

Scaler 69 has the delayed trigger for quadrant 1 and scaler 77 has the particle- $\gamma$  coincidence for that quadrant. Scalers 70 and 78 have the corresponding signals for the second quadrant etc.

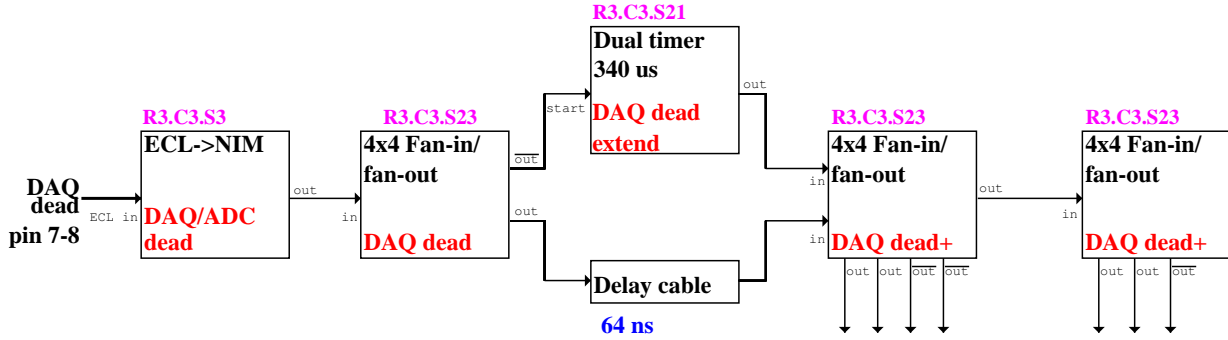

Figure 5: The generation DAQ dead signals.

## 7 Generation of the DAQ dead signals

The VME trigger module has an ECL output indicating that the DAQ is dead on pins 7-8 (note that pins 1-2 are the lower ones and 15-16 the upper ones). This goes through an ECL to NIM converter, after which it is split into two. One part is delayed by a 64 ns cable and the other part is used to start a gate at the end of the DAQ dead time. The idea is to extend the DAQ dead produced by the VME trigger module by a fixed amount. If we were to do this without the delay, we might get a short glitch where it goes not dead between the end of the output from the VME trigger module and the beginning of the extension. After that it is fanned out.

In 2007, the DAQ dead extend was 340  $\mu$ s.

This bit was changed quite a lot between July and November 2004. We use seven DAQ dead signals, three of which are inverted. These come from the top two halves of the fan-in/fan-out in R3.C3.S23. The four normal outputs are used to veto the LeCroy 465 AND modules in R3.C2.S13 and R3.C2.S15 (one for each quadrant of the CD - note that the ANDs are triple modules, so the three quadrants are on one module and the fourth on the other). The three inverted outputs are used to generate the “not busy” signal (R4.C4.S11), the “DAQ trig if DAQ not busy” (R3.C2.S15) and the “Ion and not DAQ dead” (R3.C3.S19).

## 8 Generation of the DAQ trigger

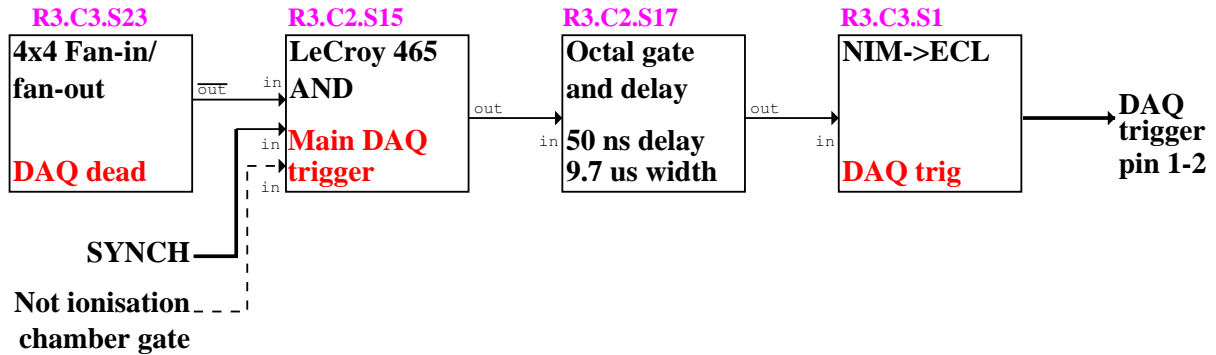

Figure 6: The generation DAQ trigger. The ionisation chamber part is shown dashed because it was not present for all experiments.

We use the DGF SYNCH to trigger readout (having ensured that we force a SYNCH at the end of the on/off window etc. - see section 21) However, if we send a DAQ trigger while the DAQ is busy, the trigger module ignores it, so we need to postpone the DAQ trigger until the DAQ is no longer busy, otherwise it hangs. Since the SYNCH remains set until readout occurs, we AND this signal with the inverted DAQ dead signal, so that the moment we have both SYNCH and the DAQ is live, we generate a DAQ trigger.

The NIM  $\rightarrow$  ECL converter module is the same one used for the ADC busy lines and we have a special flat cable which connects the four ADC busy lines and the DAQ dead output from the VME trigger module to different channels of this unit. We use the first trigger (pins 1-2, which are the lower ones of the ECL input on the VME trigger module).

It seems that between July and November 2004, this bit was changed a little, presumably to prevent deadlocks in the DAQ.

## 9 Generation of the ADC gates and the TDC stops

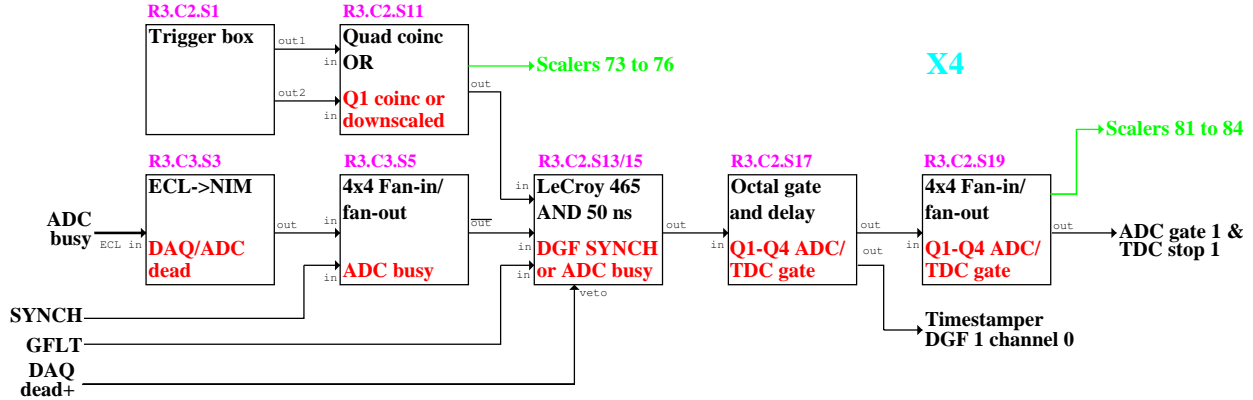

Figure 7: The generation of the ADC gates and TDC stops. Note that we have separate gates for each quadrant of the CD. This diagram shows the connections for the first quadrant. For the second quadrant we use channels 3 and 4 of the trigger box and so on. Note that for the MADC32, the busy signal is NIM, so the ECL to NIM converter is not needed.

In 2003 the ADC gate and TDC stop was the same for all parts of the CD, but in 2004 we changed it to have separate gates for each quadrant.

We want to generate an ADC gate, a TDC stop and a signal for the timestamper DGF corresponding to a given quadrant (four separate gates, four separate stops and four timestamping DGFs) all of the following conditions are satisfied:

- The trigger box gave a signal for that quadrant. Note that we can have both downscaled particle and particle- $\gamma$  coincidence for the quadrant and these need to be ORed together.
- We are in the on window or the off window. This is the equivalent of the GFLT signal sent to the DGF.
- The ADC for that quadrant is **not** busy.
- The DGF is **not** busy (indicated by the DGF SYNCH signal).
- The DAQ is **not** dead (indicated by the VME trigger module).

The ADC busy signal is provided via a special flat cable which takes the ECL signal from each ADC to a single ECL  $\rightarrow$  NIM converter. Note that the DAQ dead signal coming from the VME trigger module is also on the same cable and uses the same ECL  $\rightarrow$  NIM converter.

Note also that in 2003 we generated an artificial ADC busy which started at the same time as the real one, but lasted longer. In 2004 we used the real ADC busy signal.

The ADC gate is taken directly from the fan-in/fan-out module at the end of figure 7 and sent to the Mesytech MADC32 gate input. Then another cable goes from the gate output to the TDC corresponding to the same quadrant.

Note that the width of the output of “DGF SYNCH or ADC busy” (R3.C2.S13/15) needs to be set to about 50 ns, not for the sake of the ADC gate and TDC stop, whose signal width is determined by the gate generator, but because these signals are ORed together to make the “Si OR” signal which is used as the pattern unit’s control signal. Since there is only a fan-in/fan-out between the “DGF SYNCH or ADC busy” and the pattern control, it is here where we set the width for the signal going into the pattern unit, which needs to be at least 50 ns.

## 10 Generation of the EBIS window

Note: The “EBIS window” is the window provided by a signal from the EBIS saying there is a bunch of particles incident on the target. The terms “on window” and “off window” refer to two measuring periods of the same length, one on beam the other off beam. Consequently “EBIS window” and “on window” are synonymous terms.

A TTL signal is sent from the EBIS which after conversion to NIM is used to generate an 800  $\mu$ s gate. The length of this gate needs to be set for the particular experiment to match the opening time of the EBIS gate.



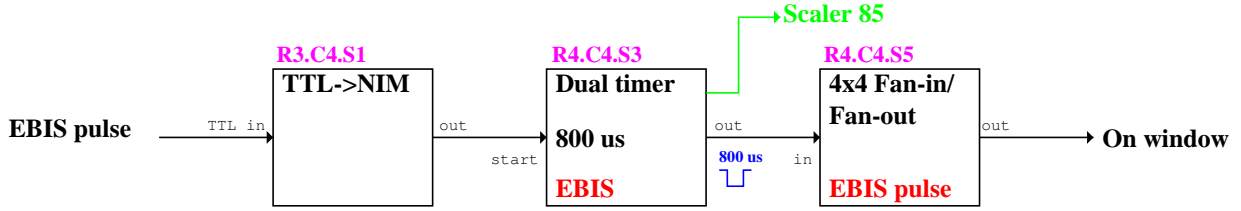

Figure 8: The generation of the EBIS window (on window)

For some reason, in 2006, we found that the dual timer was sometimes triggering on the trailing flank of the EBIS pulse as well as the leading flank, so we put it through a discriminator with a width longer than the width of the signal sent to us from the platform. Note that in this particular case, the pulse coming from the platform was 1.2 ms long, while the EBIS gate was 800  $\mu$ s long. There was no point in increasing the EBIS gate to 1.2 ms, because there were no particles during that time.

## 11 Generation of the off window

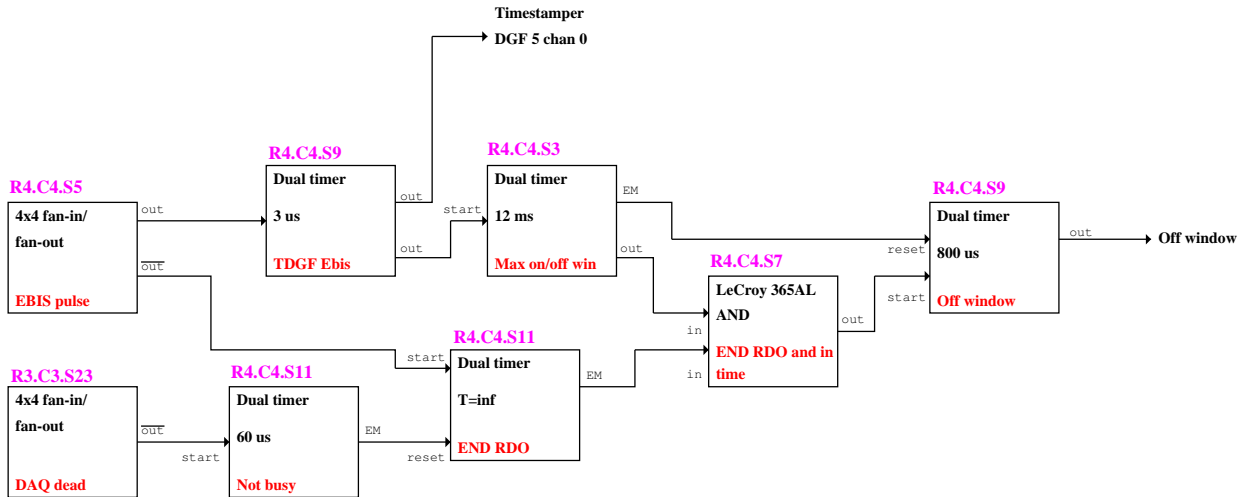

Figure 9: The generation of the off window

We want to open one window when the EBIS gate is open (the on window) then read out the data and then open a second window (the off window) in the gap between EBIS pulses and read that data out in time to be ready for the next EBIS pulse. The on window and off window must be of equal length, so the off window length needs to be set to same as the EBIS gate.

When the EBIS signal comes, we send a 3  $\mu$ s pulse to the timestamping DGF (note that this was 5  $\mu$ s in 2003) and start a gate which is closed by the end of readout (the readout being forced at the end of the on window). We also start another gate, called “max on/off window”, which is closed before the next EBIS pulse (12 ms in this case, but again this has been 10 ms or 12.25 ms in other experiments). This is used to truncate the off window, so we should also allow some time for reading out the off window data, in order to be ready to acquire when the next EBIS pulse comes. However, normally, it should be possible for the off window to close and readout to complete long before the next EBIS pulse.

Note that the length of the max on/off window should be checked for each experiment. It has to be long enough that there is an on window for each off window, but short enough, to make sure that the off window never gets in the way of the next EBIS pulse (only an issue at high repetition rates).

You can check this easily on the scope by triggering with “EBIS pulse” and looking at “max on/off window” and “GFLT”. You should then see one GFLT pulse when the EBIS pulse comes and a second one after it, but before the end of the max on/off window. If max on/off window is too short, this second pulse is suppressed (N.B. the DAQ must be running too, since it is the readout after the off window, which triggers the on window).

In the setup, we use the fact that the end of the on window triggers readout, causing the DAQ to become dead for a while, so we wait until the DAQ is not dead again after the on window.

We start the off window 60  $\mu$ s after the end of readout (obtained from the disappearance of the DAQ dead signal) to allow the ADCs and TDCs time to start. Note that originally, it was 1  $\mu$ s but it seems

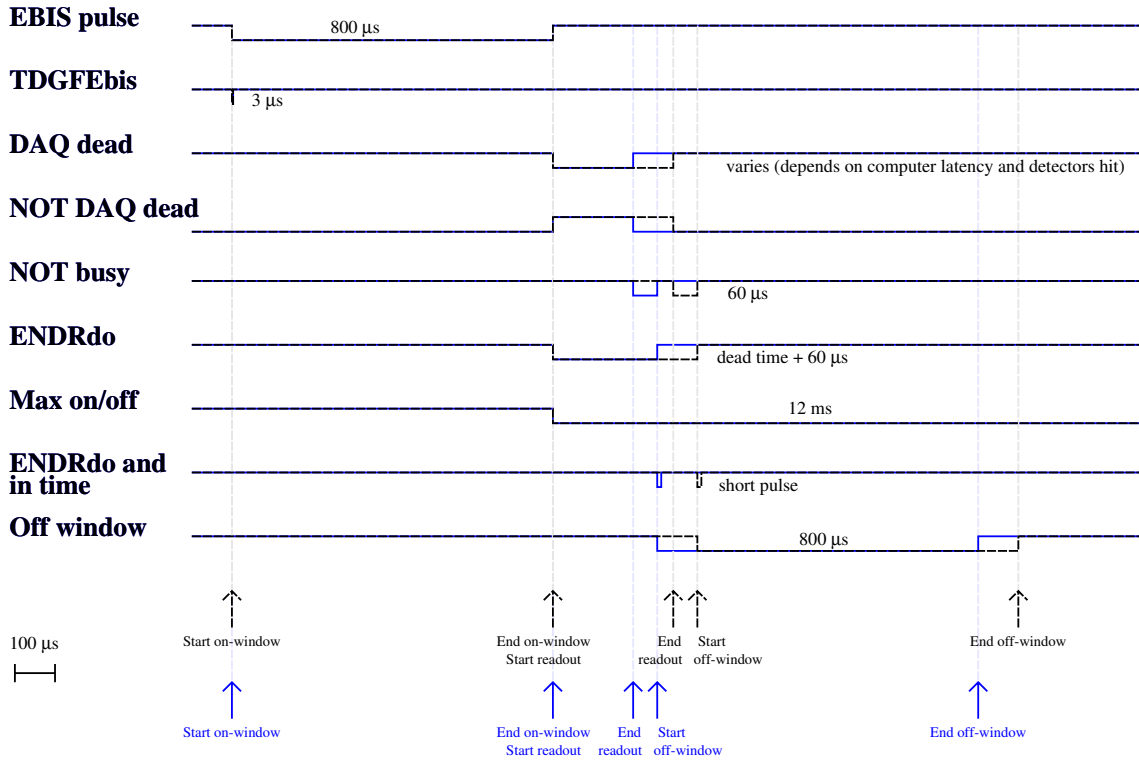

Figure 10: The timing of the off window - the different colours correspond to two different dead times.

that this is not enough time for everything to be ready. Since we have 12 ms in which to open the window, this extra delay isn't a problem. Until we increased this value, the DAQ would hang from time to time. Afterwards it didn't hang nearly as much.

The on window and off window should be of equal length. It is possible to have an on window without an off window, but not the other way round, since the off window is triggered by the first readout within about 12 ms after the on window. Consequently, if there is no on window, the off window also disappears. You should try to avoid this, if possible, by setting the max on/off window appropriately.

To set the two windows to the same width, the easiest thing is to look at the GFLT signal on the scope and if they are not the same length, you will see one width half the time and another the rest of the time, so the trailing edge of the pulse has two vertical lines. When it is correct, you only see a clean NIM pulse. Or you can look at the values of the scalers 1 MHz and on win and 1 MHz and of win, when using the 10 Hz clock as a fake EBIS signal. The former should be 8000 and the latter 16000.

### 11.1 Multiple off-window mode

In 2008, we did some experiments where the EBIS was triggered by the proton pulse i.e. once every 1.2 seconds at most, but with some of those pulses missing (we had 20 pulses out of 40 in the supercycle, but not equally spaced, so sometimes there was 1.2 seconds between pulses and sometimes as much as 4.8 seconds). We were interested in measuring the radioactive decay after the beam pulse, in order to determine beam composition. However, in the normal configuration of one off window for each on window, this wasn't possible.

So we used a new mode of operation, where the off window is generated not by the EBIS pulse, but by the GFLT signal. This means that an off window is generated not just 60 μs after the end of the readout following an on window (i.e. EBIS pulse) but also following an off window. So then we get an on window followed by a series of off windows up to the limit set by max on/off window. Furthermore, we increased max on/off window from the usual 12 ms to about 1 s (keeping it short enough that it is less than the gap between proton pulses i.e. 1.2 seconds, by enough to allow plenty of time for readout).

To do this, we unplugged the signal coming from the normal output of the EBIS pulse (R4.C4.S5) going to TDGF Ebis (R4.C4.S9) and instead triggered TDGF Ebis from the GFLT output (R4.C4.S13). Then we extended max on/off win (R4.C4.S3) to 1 second.

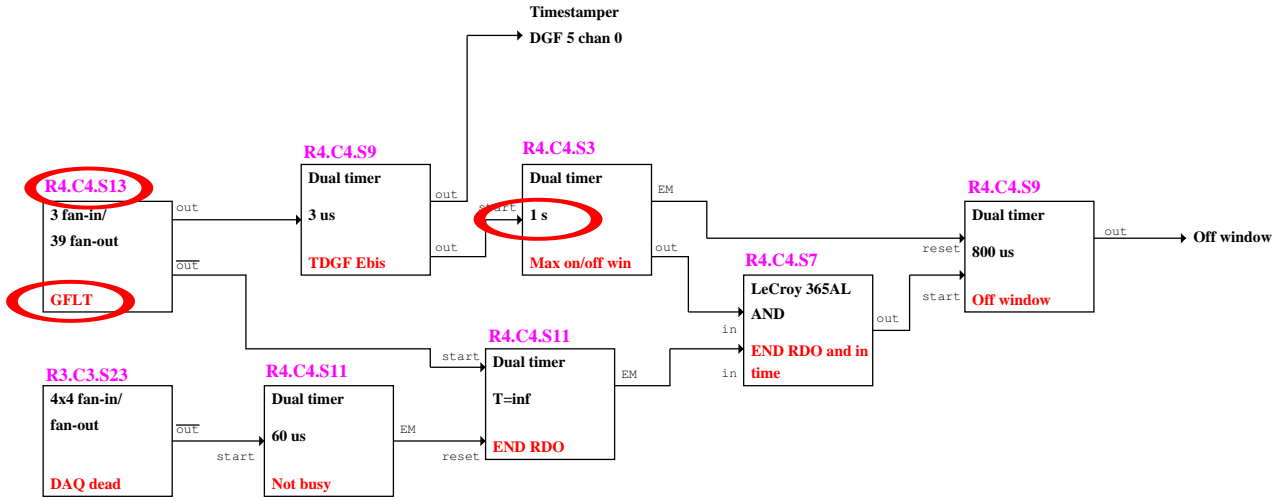

Figure 11: The generation of the multi-off window. The differences compared to the normal off window are highlighted with red ellipses

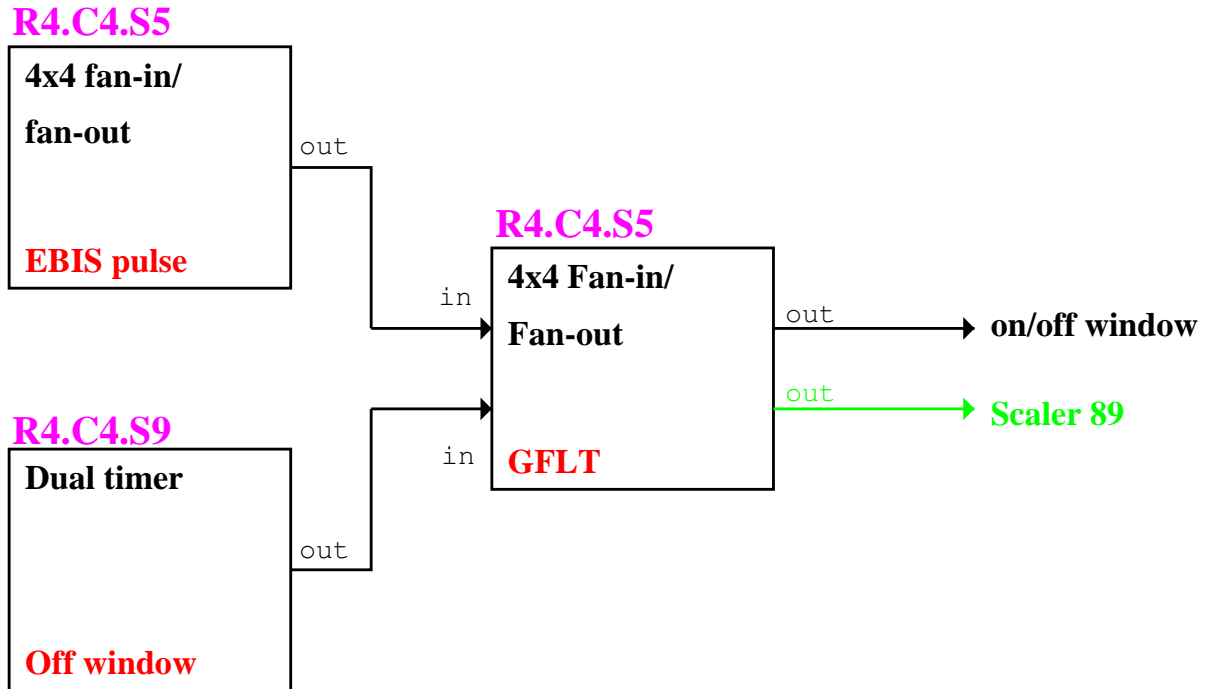

Figure 12: The generation of the on/off window

## 12 Generation of the on/off window

The on/off window is simply the logical OR of the on window and the off window. It is used to generate the GFLT, so the terms “on/off window” and “GFLT” are synonymous.

## 13 The generation of the GFLT

The global first level trigger (GFLT) signal which is sent to each DGF is the same thing as the on/off window. We use two 3 fan-in 39 fan-out modules to distribute the signal.

Typical times would be 800  $\mu$ s on window then about 3.2 ms readout and finally 800  $\mu$ s off window. The on and off window lengths should be equal and fixed. The readout time varies depending on the events.

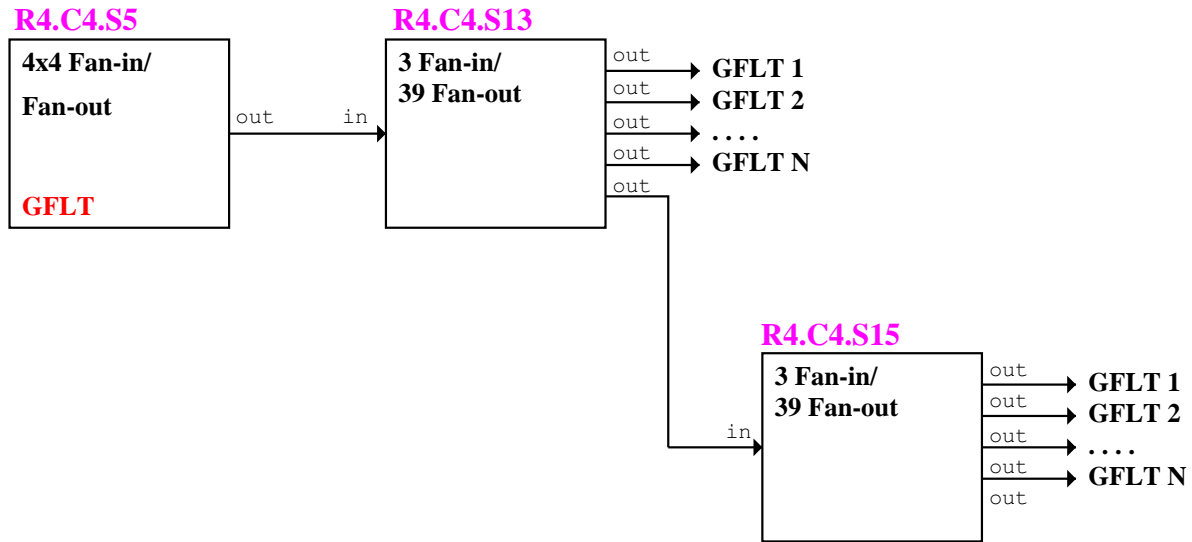

Figure 13: The generation of the GFLT from the on/off window

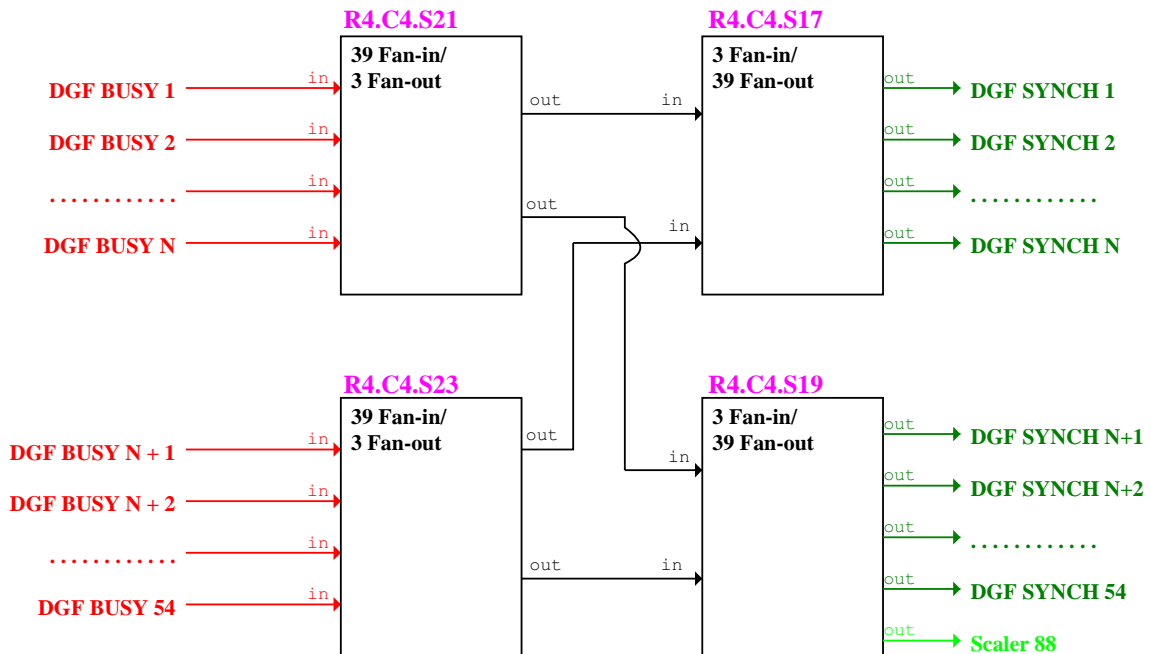

Figure 14: The DGF BUSY/SYNCH loop

## 14 The DGF BUSY/SYNCH loop

The DGF BUSY/SYNCH loop is made using two 39-fan-in/3-fan-out modules and two 3-fan-in/39-fan-out modules. We take all the BUSY outputs from the DGFs and feed them into the fan-in inputs and then take the outputs to the fan-outs and send the result to each SYNCH input. In this way, if any one DGF is BUSY, the SYNCH line is set to logic one and if all the DGFs are acquiring it is logic zero.

## 15 Changes for the Mesytech MADC32 modules

Like the DGFs, the Mesytech has an input which can be used to reset the clock. However, they do work in quite the same way, so they cannot be directly integrated into the BUSY-SYNCH loop.

The BUSY/CBUS output of each Mesytech module (R2.C1.S4-7) is connected to the inputs of each of the four parts of the fan-in/fan-out "ADC busy or SYNCH" module in R3.C3.S5. This is the same as for the CAEN modules, as shown on figure 7, except that while the CAEN V785 modules produce an ECL

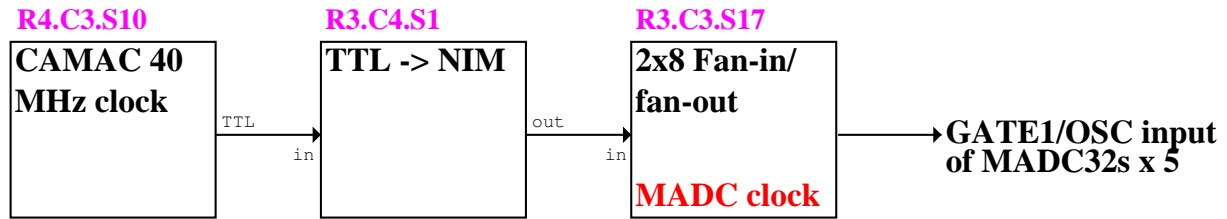

Figure 15: The generation of the 40 MHz clock signal for the MADC

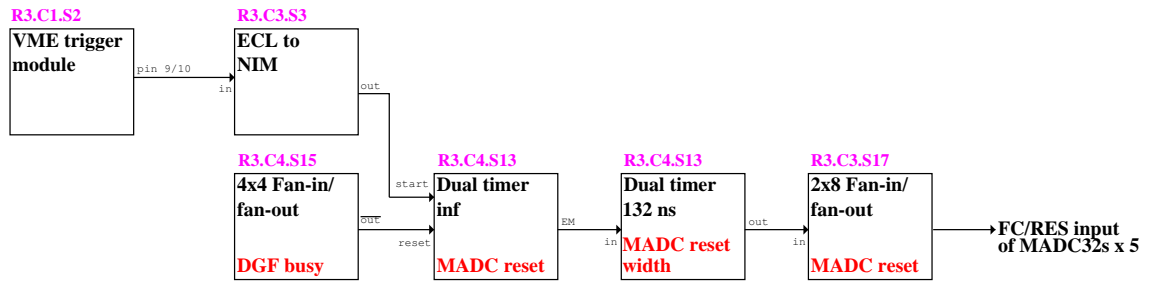

Figure 16: The MADC32 clock reset

signal, which has to be converted to NIM by the converter in R3.C3.S3, the Mesytech modules generate NIM directly.

The GATE0 input takes the same gate signal as the CAEN V785 from R3.C2.S19, which is also the TDC stop.

The GATE1/OSC input receives the 40 MHz clock, which is taken from a fan-in/fan-out module in R3.C3.S17. This module is in 2x8 mode, because we have five Mesytech MADC32s, which must receive this clock. The input comes from the TTL to NIM converter in R3.C4.S1 and its input comes in turn from the 40 MHz clock module in R4.C3.S10 (i.e. the module which distributes the 40 MHz clocks to the DGFs in that crate). See figure 15.

The FC/RES input is used to reset the clock of the Mesytech module. This signal comes from the second half of the 2x8 fan-in/fan-out module in R3.C3.S17. Again, as we have 5 Mesytech modules, we need five outputs from this module. The input for this module comes from the normal output of the lower part of the dual timer in R3.C4.S13. This part is used just to generate a signal of the appropriate width (set to 130 ns) and is started by the end marker of the upper part of the same module. The upper part is started by the DAQ Go signal and reset by the inverted output of the “DGF busy” signal from R3.C4.S15 with the range set to infinity. i.e. we start the dual timer when the DAQ starts and stop it when the “DGF busy” (which is the logical OR of all the busy outputs of the DGFs) becomes not busy (i.e. the moment when the DGFs reset their clocks) and at that stage it generates the end marker, which is given a long enough width in the lower part of the dual timer and set to the FC/RES input of the MADC32. See figure 16.

The DAQ Go signal is taken from output 6 of the ECL to NIM converter in R3.C3.S3. This module has a flat cable input, which is split into individual twisted pair wires. The first four are for the ADC busy lines of the CAEN V785 modules, which are not used when the Mesytech modules are used. The fifth one is for DAQ dead which is connected to pins 7 and 8 of the VME trigger module (R3.C1.S2) and the sixth one is

the DAQ Go, which is connected to pins 9 and 10 of the same VME trigger module.

The signal cables (flat cables) are connected in the same way as the CAEN V785 modules.

## 16 Note about special signals

We get several signals from different parts of the REX ISOLDE setup. When ISOLDE is running, we get a T1 signal when a bunch of protons hits the ISOLDE target, then a T2 signal when the gate is opened allowing beam from ISOLDE into REXTRAP. Since these two signals are correlated one-to-one with a fixed time delay between them, it is not necessary to have both. If the laser is running in on/off mode, we get a signal indicating laser on or laser off (sent into the pattern unit).

Note: The T1 and T2 signals are different for each separator (HRS and GPS). You need to hook them up in the ISOLDE control room for the appropriate separator.

The individual bunches of protons hitting the ISOLDE target form part of a supercycle and we receive the PS signal indicating the start of each supercycle. Comparing the T1 pulses to the PS signal indicates how many bunches we receive in each supercycle.

Once the ions have been trapped in the REXTRAP and ionised in the EBIS, the EBIS gate is opened to allow them into the REX accelerator. We receive the EBIS gate signal which indicates when ions are released from the EBIS and which is directly correlated to our beam. Consequently, we use this signal to generate the on-beam window.

## 17 Generation of the T1 timestamp

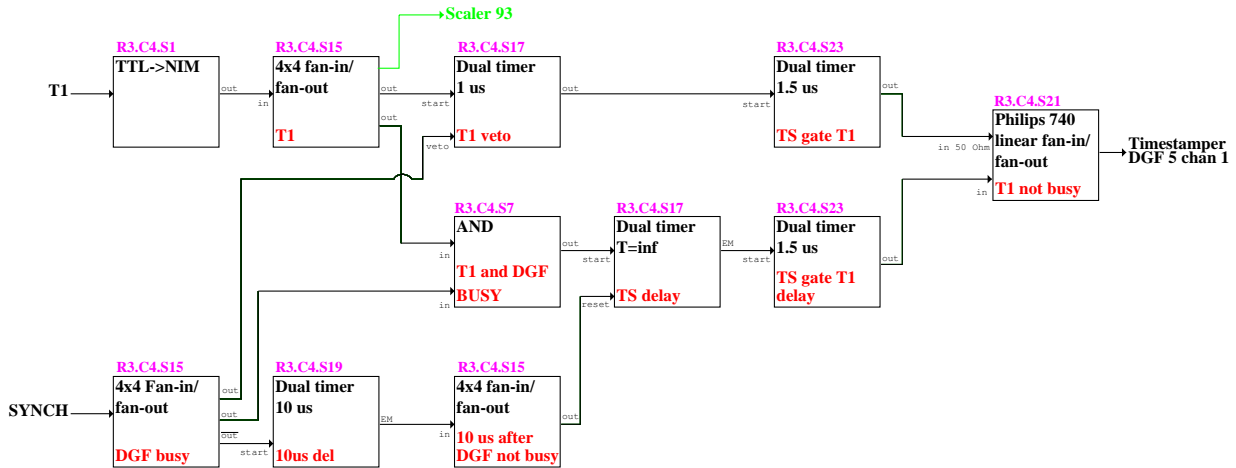

Figure 17: The generation of the T1 timestamp. Note that the three modules at the bottom are the same ones used for the T1 timestamp (see 19).

We want two signals:

- the timestamp of the T1 signal itself, which we obtain by converting it from TTL to NIM and then generating a gate which we send via a linear fan-in/fan-out to the DGF but vetoed by the DGF busy.
- The timestamp of a time  $10 \mu\text{s}$  after the DGF starts acquiring after a T1 pulse.

In order to distinguish the two signals, they are combined using a linear fan-in/fan-out, but with one of them attenuated using a LEMO T-piece with a  $50 \Omega$  terminator.

The T1 timestamp is produced in a similar way to the proton supercycle timestamp. Both use the “ $10 \mu\text{s}$  after DGF not busy” signal, so the bottom three modules in figures 19 and 17 are the same.

## 18 Generation of the proton supercycle timestamp

We want to generate a DGF timestamp giving the time of arrival of the proton supercycle start signal and a time  $10 \mu\text{s}$  after the first readout after a proton supercycle start signal.

We receive an TTL signal each time that we get a proton supercycle start which we feed into an TTL  $\rightarrow$  NIM converter. We do two things with this signal.

- Firstly, we use the signal to start a direct gate to indicate the start of the proton supercycle, which we send via a linear fan-in/fan-out to a timestamping DGF.

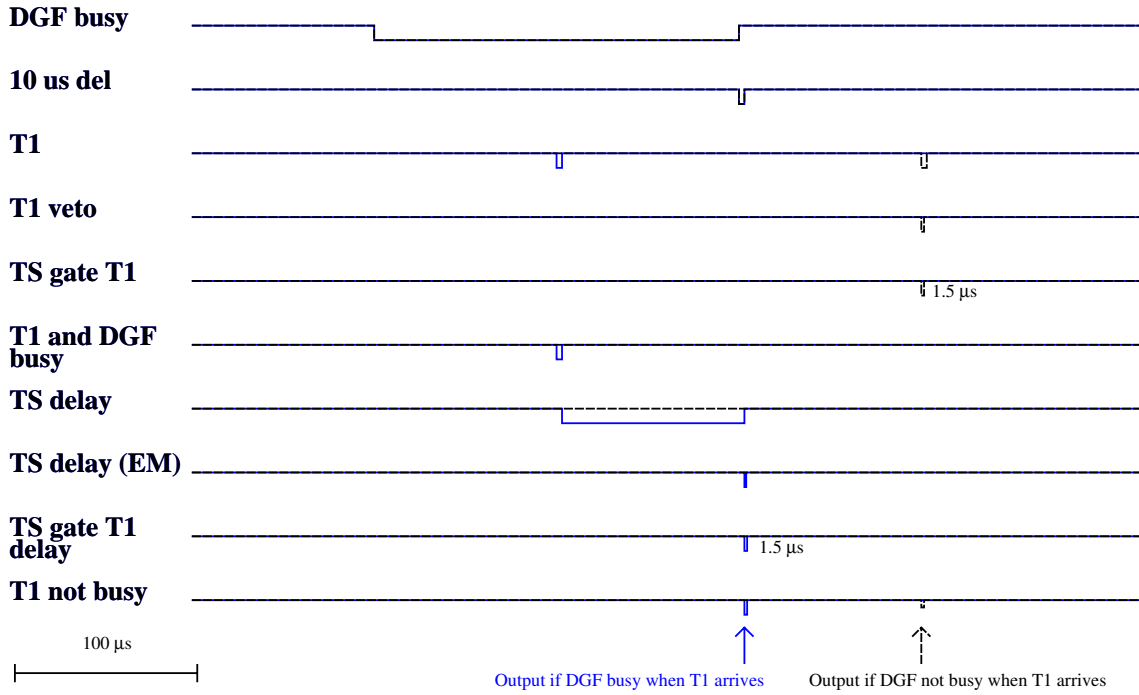

Figure 18: Timings for the T1 timestamp. If the DGF is not busy, when T1 comes, we generate a signal for the DGF at once, otherwise we wait until  $10 \mu\text{s}$  after it becomes not busy. In order to distinguish the two cases, we attenuate the direct one. The different colours show these two cases.

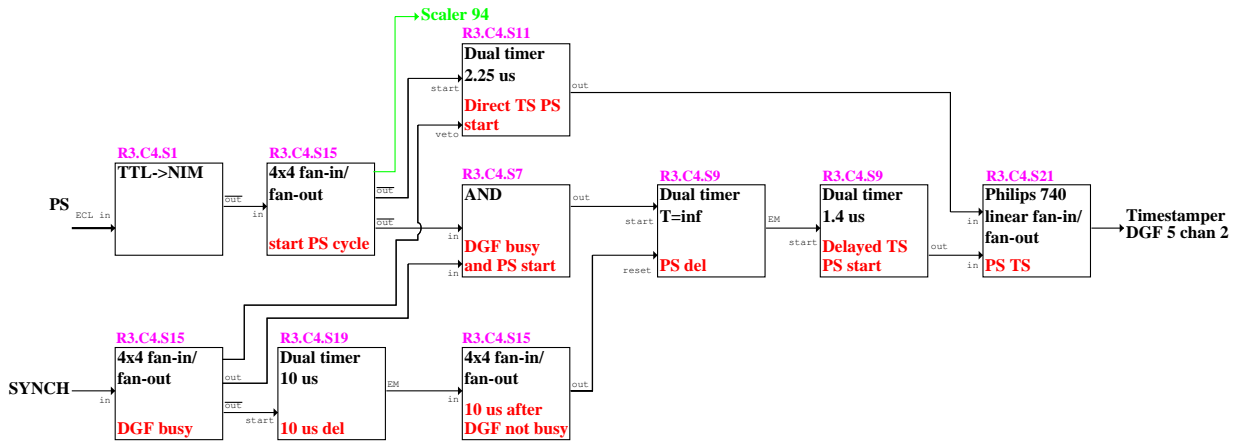

Figure 19: The generation of the proton supercycle timestamp. Note that the three modules at the bottom are the same ones used for the T1 timestamp (see 17).

- Secondly, we want the timestamp for the first time the DGF is not busy after a supercycle start. To get this, we start a timer when the supercycle starts and the DGF is busy, and reset that timer  $10 \mu\text{s}$  after the DGF is no longer busy. Then we use the end marker of that timer to generate a gate, which is sent to the same timestamping DGF via the linear fan-in/fan-out.

Note that the bottom three modules of figures 17 and 19 are the same. i.e. they share the same  $10 \mu\text{s}$  delay.

Why don't we attenuate one of the two inputs to the linear fan-in with a  $50 \Omega$  piece in order to get different pulse heights for the two kinds of signal? We do this with the T1 signal and it seems that we should do it to PS as well. I am told this isn't really that important for PS.

I notice that in May 2005, the inverted output from the TTL to NIM converter is being used. This must have already been like that in November 2004, but I'm not sure if it was like that in July 2004. My notes from July 2004 indicate we used the normal output, but this could be an error. In any case, now we use the inverted output.

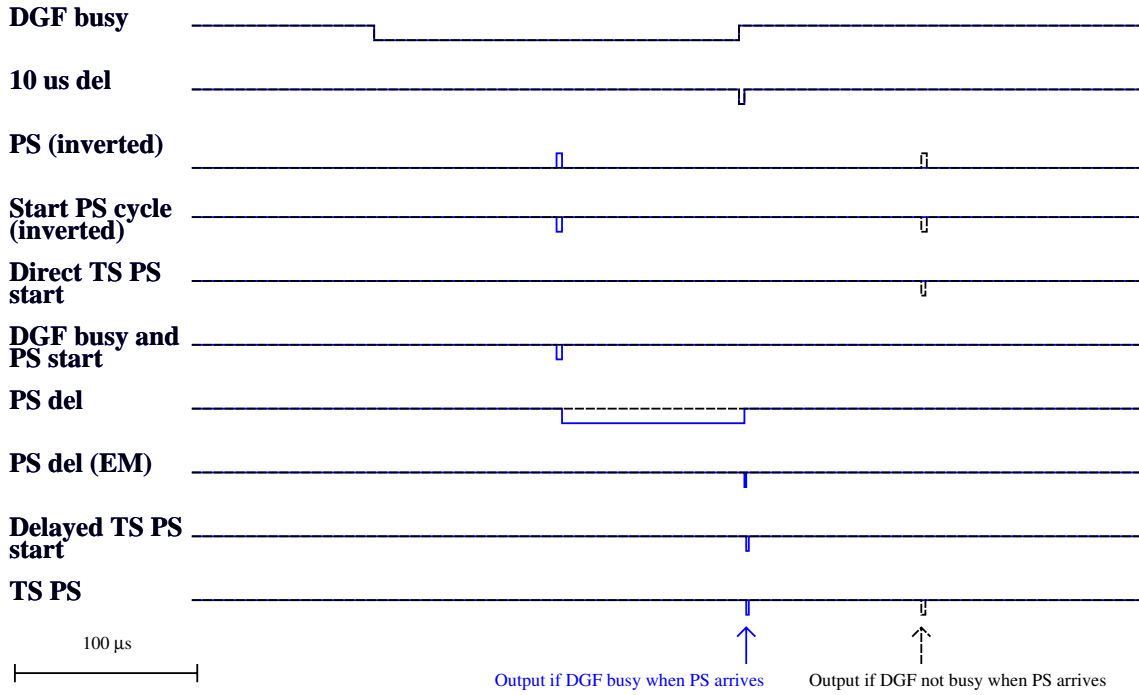

Figure 20: Timings for the proton supercycle timestamp. We generate a pulse for the DGF either when the PS signal comes if the DGF is not busy or  $10\ \mu\text{s}$  after it becomes not busy, if it was busy when the PS signal comes. The different colours show these two cases.

## 19 Generation of the control signals for the scalers

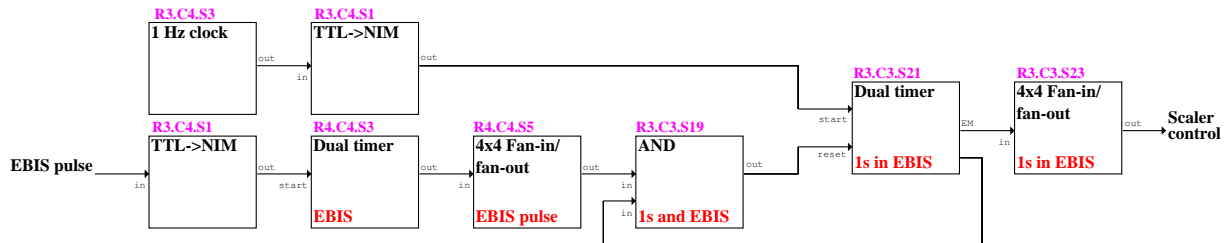

Figure 21: The generation of the control signals for the scalers

Normally, we want to read out the scalers every second. We convert a 1 Hz clock pulse into NIM and use it to start a gate which we fan out to the control inputs for the three scalers.

However, we only want to read when the EBIS pulse comes (on window), so we use the end marker of our gate and reset it with the EBIS pulse.

There was another change here between July and November 2004. An extra AND module was inserted between the fan-in/fan-out module called “EBIS pulse” and the reset for the “1 s in EBIS” dual timer. The other part of the AND comes from the output of that dual timer, so the timer is only reset if it is actually running.

Note, that in 2007, I found that this had been changed from infinity to 316 ms. This is presumably to ensure that the scalers still tick, even if the EBIS is off and as long as the EBIS is running at a higher frequency than about 3 Hz, the dual timer will still be reset by the EBIS pulse before this time is reached. Probably, this was only set to make it possible to debug when the EBIS was off (though normally, we use a fake EBIS pulse for this).

### 19.1 Scalers in proton-triggered mode

In 2008, we did some experiments where the EBIS was triggered by the proton pulse i.e. once every 1.2 seconds at most, but with some of those pulses missing (we had 20 pulses out of 40 in the supercycle, but not



equally spaced, so sometimes there was 1.2 seconds between pulses and sometimes as much as 4.8 seconds). Reading out the scalers every second in such a configuration proved to be rather useless, so we switched to triggering the scalers from the proton pulse T1 rather than the 1 Hz signal. To do this, we unplugged the 1 Hz output from the TTL to NIM converter (R3.C4.S1) and took the signal instead from the “T1” part of the fan-in/fan-out module in R3.C4.S15.

## 20 Generation of pattern unit control signal

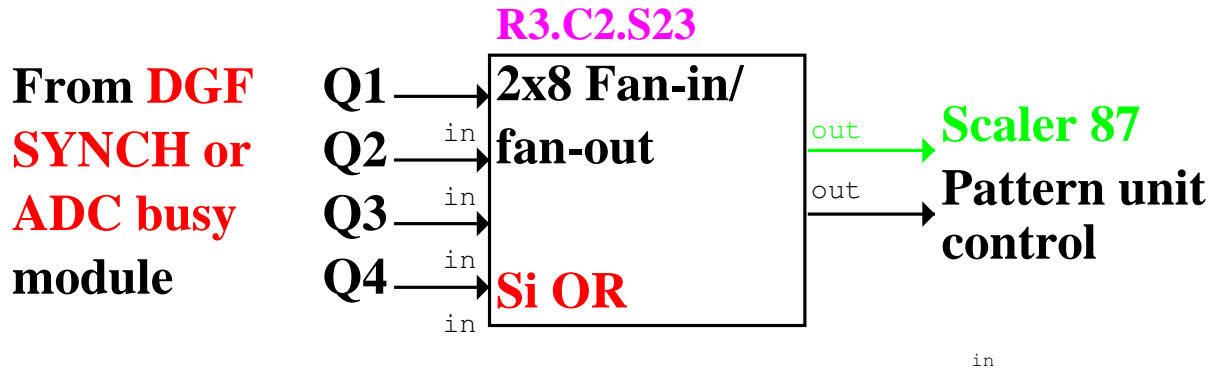

Figure 22: The generation of the control signals for the pattern unit. The four inputs come from the LeCroy 365 AND modules which generate the signal to produce the ADC gate for each quadrant, which is already vetoed by DAQ dead, ADC busy etc.

The pattern unit needs to record the pattern when each ADC gate occurs. However, we only have one pattern unit and four separate ADC gates (one for each quadrant) so we need to OR these signals logically. We take the signal out of the AND “DGF SYNCH or ADC busy” in the middle of figure 7 for each quadrant and pass them into a fan-in/fan-out. The resulting signal is the control for the pattern unit.

Note that the pattern unit needs a signal of at least 50 ns. This width is set in the “DGF SYNCH or ADC busy” modules (R3.C2.S13/15).

## 21 Generation of the forced readout

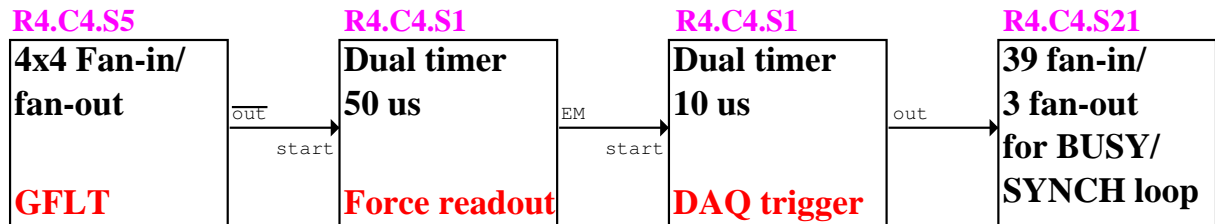

Figure 23: The generation of the forced readout

We take the GFLT signal, delay it 50  $\mu\text{s}$  and then use it to generate a 10  $\mu\text{s}$  wide pulse which we send to the fan-in of the DGF BUSY/SYNCH loop (see section 14). This causes the DGFs to finish their run and since the SYNCH is used to generate the DAQ trigger (see section 8).

Note that in 2004-5, the electronics for this were in rack 3, but they were moved to rack 4 in May 2006 in order to optimise the cables better.

## 22 The pattern unit bits

The first eight bits of the pattern unit correspond to the eight channels of the trigger box. i.e. downscaled quadrant 1, quadrant 1 and  $\gamma$ , downscaled quadrant 2 . . .

In August 2004, we added in the laser on/off signal (bit 9) into the pattern unit. Note that this bit indicates the request that we send to the laser cabin (which is ignored in manual mode) not the actual state of the shutter.

Note that the highest bits should not be used as they are used internally in the acquisition program.

| Bit | Signal                       |
|-----|------------------------------|
| 1   | downscaled quadrant 1        |
| 2   | quadrant 1 particle $\gamma$ |
| 3   | downscaled quadrant 2        |
| 4   | quadrant 2 particle $\gamma$ |
| 5   | downscaled quadrant 3        |
| 6   | quadrant 3 particle $\gamma$ |
| 7   | downscaled quadrant 4        |
| 8   | quadrant 4 particle $\gamma$ |
| 9   | Laser on                     |

## 23 Laser on/off

The laser on/off signal is generated from the PS signal, because we want to synchronise with a proton supercycle. The idea is to switch alternately one supercycle laser on, one supercycle with laser off.

In 2003 and 2004, a TTL signal was sent to the laser cabin and used to switch the laser on and off. The box in the laser cabin had a switch “TTL/MAN” which in TTL mode responded to this signal and in MAN mode remained either continuously open or closed according to the state of a second switch (which we left always “open”). The same signal which was sent as TTL to the laser cabin was sent as ECL to the pattern unit. The problem with this is that this means the acquisition records the state that the laser shutter should be in if set to TTL mode. However, if the switch is set to manual, the pattern unit still sees the alternating on/off cycle, even though the shutter is not moving. Furthermore, in 2004 we had the situation where the shutter itself jammed and then the acquisition recorded the state the shutter should have been in, not the actual state.

Another shortcoming of the setup in 2004 was the use of a timer to determine the length of time the shutter should stay open or closed. In fact, the supercycle length varies depending on the number of pulses per supercycle. Also, we don’t know if the time between the arrival of the PS signal and the opening of the shutter is short enough if we get the first pulse in the supercycle. It is possible that the laser shutter isn’t open fast enough, so that the first pulse is effectively in laser off mode, even though the bit says we are in laser on mode. This is not a problem if somebody else gets the first pulse and we get later ones.

In May 2005 a new system was installed. Now the PS signal is sent directly to some electronics in the laser cabin which does the switching automatically. This electronics is controlled by a control box in R1.C4.S13, to which it is connected by three cables. Depending on the position of the control on this module, the electronics in the laser cabin either sets “laser on”, “laser off” or “laser on/off” (i.e. switching at each supercycle) modes. This means we don’t have to go to the laser cabin in order to switch between laser on and laser on/off modes.

In addition, there is the laser status signal, which indicates the status of the shutter measured using an optical sensor. In 2005 this was a TTL signal which went through the TTL to NIM converter in R3.C4.S1 and from there up to the pattern unit. In 2006, it was a NIM signal which went directly from the laser cabin, via the control room and the patch panel on the wall into the pattern unit.

In 2007, there was a new shutter, so it was no longer possible to get a feedback of the actual shutter status. Instead, the laser status merely indicates what we have requested. This signal goes through a TTL to NIM converter in R1.C4.S17 and then into the first part of the logic fan-in/fan-out in R3.C4.S5. The inverted output is sent to the pattern unit bit 9 (N.B. the signal from the laser cabin has the opposite polarity compared to 2006, which is why we take the inverted output, so that the bit still is set to mean laser on and cleared to mean laser off as before). An additional copy of this signal (not inverted) is used to veto the 1 MHz (from the same module) using the coincidence module in R3.C3.S19. So this module has only one active input (1 MHz) and the veto (laser not on).

## 24 1 MHz and EBIS, 1 MHz and GFLT

For some reason these signals weren’t documented in 2004. We simply take the logical AND of the 1 MHz clock signal (after conversion from TTL to NIM) and the EBIS signal. Since the EBIS signal is equivalent to the on window, this counts the number of microseconds in the on window. This result is sent to scaler 91. Similarly, we take the AND of the 1 MHz clock and the GFLT, which is equivalent to the on/off window and send it to scaler 92.

This means that we use scaler 90 to measure the time between scaler readouts in microseconds, scaler 91 to give the amount of time the on window was active in that period and scaler 92 gives the sum of the on window and the off window.

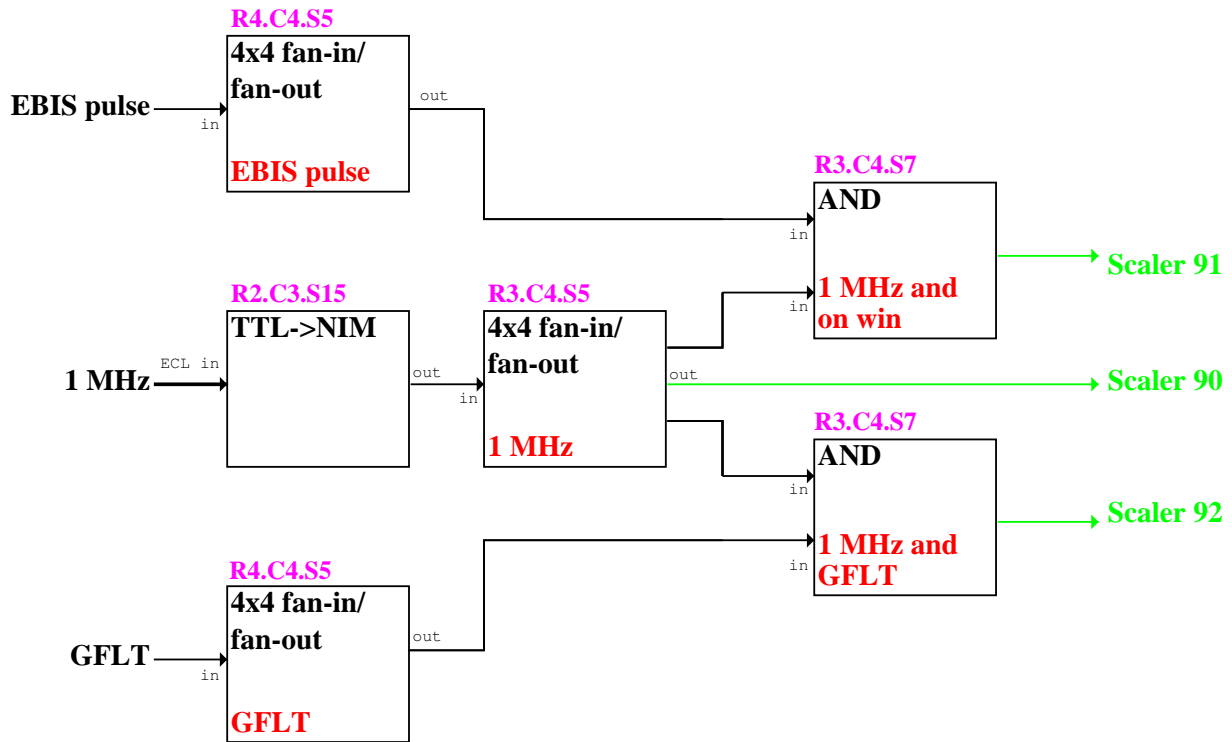

Figure 24: The 1 MHz signals.

## 25 The DAQ crash reset

In previous years we have frequently observed that the DAQ gets stuck and glitching the button on the coincidence module in R3.C2.S15 would get it going again.

The explanation is probably that this module is used to generate a pulse when the level of the DGF BUSY goes from not busy to busy. This in turn is used to send an interrupt to the power PC to start readout. What we think is happening is that under certain circumstances, the power PC is not ready when the interrupt comes, so it misses it. Then because the levels don't change, no new pulse is generated. Glitching this signal, causes the level to change briefly, creating a new pulse, which triggers the DAQ.

In 2009 we have tried adding a new feature to perform an automatic reset in this case. We take the logical AND of the DGF synch signal (from R4.C4.S17) and the GFLT (R4.C4.S13) using the 4-fold logic unit in R4.C4.S7. The output from this module is fed into the "DAQ dead" fan-in/fan-out in R3.C3.S23. In normal operation, we shouldn't get a GFLT (i.e. an EBIS pulse or an off window) when the DGF is busy and the DAQ is not dead. But we think that when the crash occurs, the DGF is busy and the DAQ is not dead indefinitely, so when the next EBIS pulse comes, this will trigger a DAQ dead and lead to a readout being forced.

This is still under test. If it causes problems, it is enough to unplug the cable labelled "DAQ crash reset" from the "DAQ dead" fan-in/fan-out module in R3.C3.S23.

## 26 The Bragg chamber

Prior to 2007, the Munich ionisation chamber ran on a different beam line to Miniball and the DAQ was run in a different directory, but the electronics was set up, so it was quick to switch between the two.

In 2007, with the new beam line in the new hall, the system was changed completely. The Bragg chamber now sits permanently at the end of the Miniball beamline and it is intended to acquire it during normal acquisition, so the beam composition can be continuously monitored.

The readout is now performed by a SiS 3300 VME module (R3.C1.S20), which receives the signal from the Bragg chamber directly. In the current version of the DAQ only input 1 is used. The SiS 3300 module provides a trigger from output 1 and needs a gated trigger in input 2. The gating is done in a LRS 465 coincidence unit in NIM R3.C3.S19. Trigger from SIS3300 and DAQ not dead and GFLT.

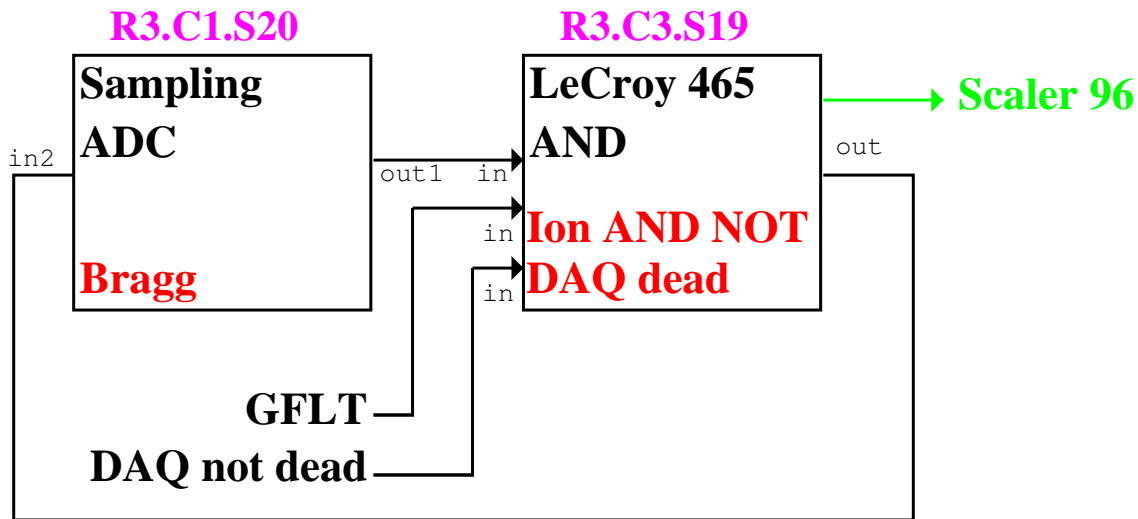

Figure 25: The electronics for the Bragg chamber

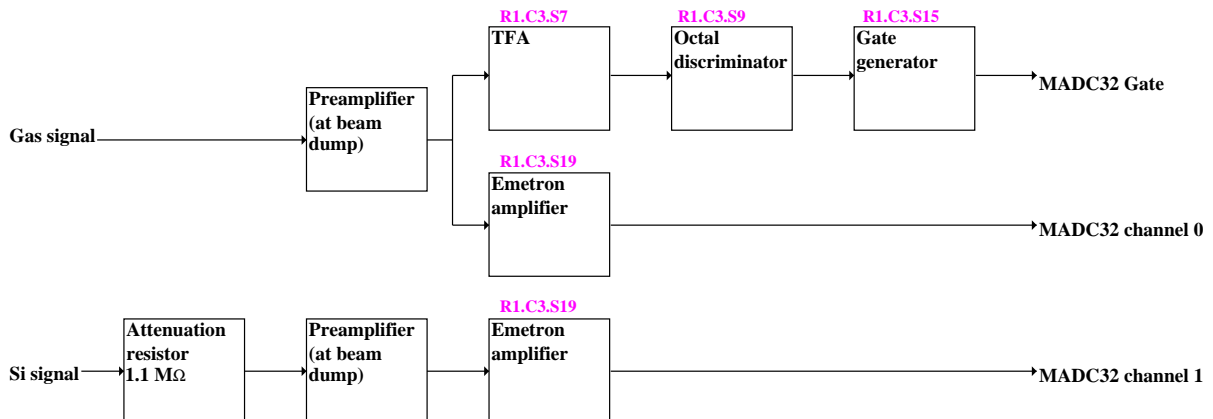

Figure 26: The electronics for the Ionisation chamber

## 27 The ionisation chamber

In 2009 we went back to using the ionisation chamber, but this time at the end of the Miniball beam line. There are two signals coming out of the ionisation chamber: the energy loss in the gas (connector at the side of the chamber) and that in the Si detector (at the back). Each of these goes into one of the channels of the preamplifier which sits right on top of the ionisation chamber.

At the electronics rack, the gas signal is split with a LEMO T-piece. One copy goes into a TFA and then one channel of an octal discriminator and from there to a gate generator, which is used to generate the gate for the ADC. The other part goes into one channel of a dual amplifier. The Si signal goes into the other channel of the amplifier and the two signals go to two channels of the ADC.

Previously, we used a CAEN V785 VME ADC, but from 2009 we used the Mesytec MAD32 instead.

## 28 DGF backplane bus

The DGFs need to have a common 40 MHz clock shared by all modules, which is connected via the backplane bus. This is generated by one of the CAMAC 40 MHz clock modules, which is set to master. Never connect an input to a module set to master. The output of the master goes to the input of another clock set to slave and its output goes to the input of a third module set to slave etc. These connections are made with IEEE-1394 (Firewire) cables at the front.

At the back of these clock modules there are three outputs which can be used to fan out to up to eight DGFs per output. So one module is enough per crate. A flat cable is used to connect each DGF to the clock with an adaptor piece at one end and a terminator piece at the other.

The DGF has two triggers: a fast trigger sent as soon as an event is detected and a slow DSP trigger sent after the slow filter time (i.e. about 10  $\mu$ s later. These are available on the same backplane bus as the 40 MHz clock. For Miniball, we have seven signals per capsule on two DGFs, and only the core is allowed to generate a signal. So the trigger lines between those two DGFs need to be connected. Then the core channel can trigger the segments in the same DGF and those in the second DGF. The trigger lines between DGF modules with signals from different clusters should be cut. To do this, physically cut out the four middle wires of the 16 wire flat cable between modules that are not for the same capsule, but leave the other wires (clock etc.) present. Note, that for the special signals for the timestamping DGFs, these are all independent, so all the trigger wires should be cut there.

Unfortunately, because the DGF bus is incorrectly terminated, it was not possible to protect the driver IC of the clock module against misconnection. So if you connect up something wrongly, you will probably blow the AD8017 driver IC for that channel. Don't then swap the channels or you will kill another one!

## 29 Scalers

There are three 32-channel scaler modules in use. Scalers 1 to 64 are for the PPAC. The third has a variety of different signals from different sources.

| Scaler | Signal     | Scaler | Signal             |
|--------|------------|--------|--------------------|
| 65     | Q1 free    | 73     | Q1 accepted        |
| 66     | Q2 free    | 74     | Q2 accepted        |
| 67     | Q3 free    | 75     | Q3 accepted        |
| 68     | Q4 free    | 76     | Q4 accepted        |
| 69     | Q1 delayed | 77     | Q1 and gamma       |
| 70     | Q2 delayed | 78     | Q2 and gamma       |
| 71     | Q3 delayed | 79     | Q3 and gamma       |
| 72     | Q4 delayed | 80     | Q4 and gamma       |
| Scaler | Signal     | Scaler | Signal             |
| 81     | Q1 gate    | 89     | GFLT               |
| 82     | Q2 gate    | 90     | 1 MHz              |
| 83     | Q3 gate    | 91     | 1 MHz and on win   |
| 84     | Q4 gate    | 92     | 1 MHz and GFLT     |
| 85     | EBIS pulse | 93     | T1                 |
| 86     | Total DGF  | 94     | PS                 |
| 87     | Si OR      | 95     | 1 MHz and laser on |
| 88     | SYNCH      | 96     | Bragg              |

## 30 Positions of modules in crates and racks

The racks are numbered from 1 to 5 with 1 being closest to the wall. The crates are numbered from 1 with crate 1 being highest. The notation R1.C2 means rack one crate two and R1.C2.S17 refers to the module in slot 17 of that crate. These numbers are shown on the circuit diagrams.

### 30.1 Rack 1

In rack 1 we have the PPAC HV supply, one camac crate without a crate controller and one NIM crate. Note that this NIM crate is the one which was in R2.C3 in previous years. It was moved to make space for the new DAQ computer.

#### 30.1.1 CAMAC crate R1.C2

- Slot 17 - LeCroy 4532 MALU (Quadrant 1 OR)
- Slot 19 - LeCroy 4532 MALU (Quadrant 2 OR)
- Slot 21 - LeCroy 4532 MALU (Quadrant 3 OR)
- Slot 23 - LeCroy 4532 MALU (Quadrant 4 OR)



Figure 27: R1.C1: PPAC power supply. We normally use about +400 Volts

### 30.1.2 NIM crate R1.C3

This crate was used for testing purposes and has nothing which was in use for the first experiment, as this was without laser operation and the laser control was not set up.

- Slot 1-2 linear fan-in/out (not used)
- Slot 3-4 empty
- Slot 5-6 empty
- Slot 7-8 Ortec TFA “Ionisation chamber gas signal”
- Slot 9-10 LeCroy octal discriminator “Ionisation chamber gas signal”
- Slot 11-12 empty
- Slot 13-14 empty
- Slot 15-16 CAEN Dual gate generator “ionisation chamber gate”, “not used”
- Slot 17-18 Pulser (not used)
- Slot 19-20 Emetron dual amplifier “Si signal”, “Gas signal”
- Slot 21-22
- Slot 23-24 Laser control unit

### 30.1.3 NIM crate R1.C4

- Slot 1-2 empty
- Slot 3-4 Level converter

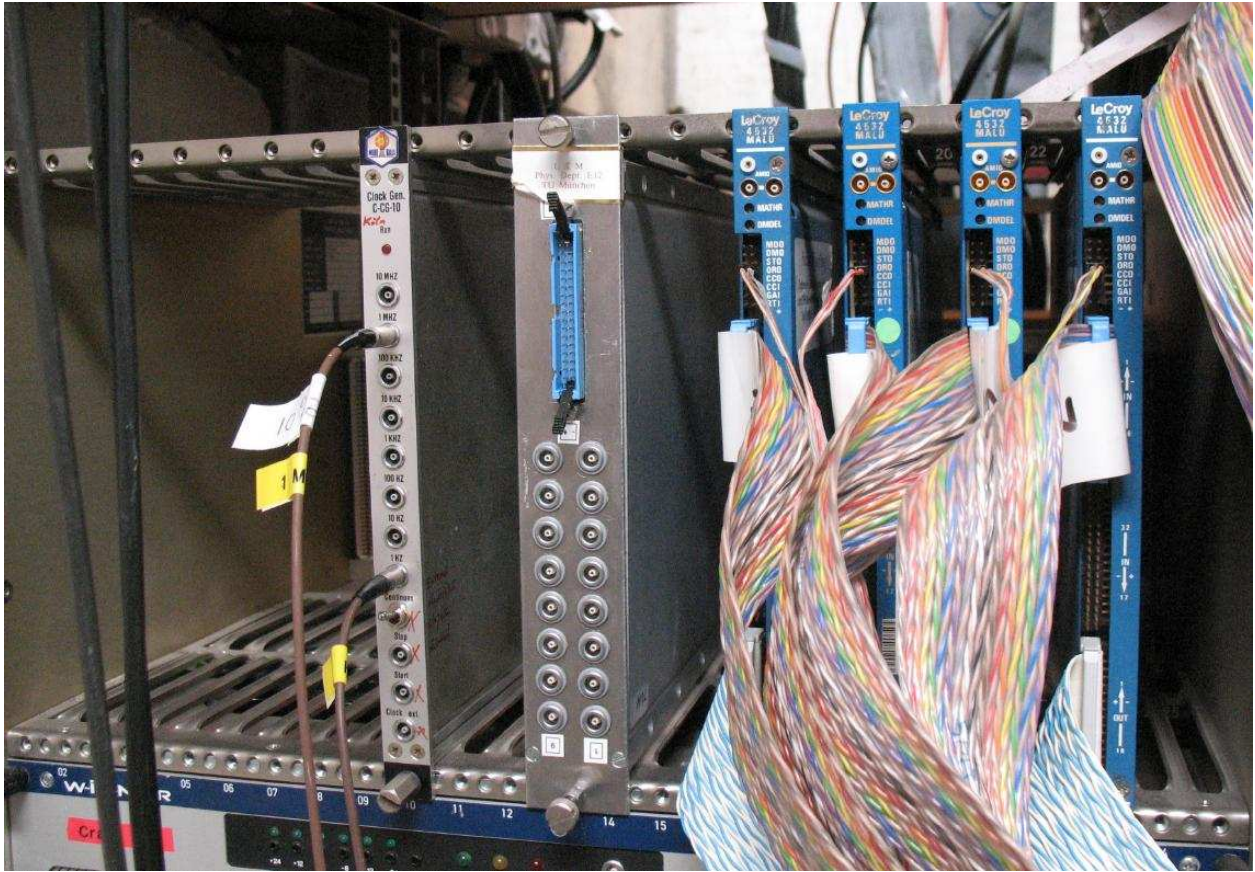

Figure 28: R1.C2: The cabling of MALUs - four multicoloured flat cables (one from each quadrant - the other ends are split in pairs, so they go to 8 RAL109s) come from the RAL109s in R2.C2 (i.e. the front rings) to the inputs. Four blue and white flat cables go from the outputs of the MALU to the TDCs. The ORO output of each MALU goes to the ECL→NIM converter (R1.C4.S23). The clock module provides 1 Hz and 1 MHz TTL pulses. The NIM module in this crate is not plugged in. It is just there for storage.

- Slot 5-6 Silena quad bias supply (CD bias)
- Slot 7-8  $\pm 24$  Volt power
- Slot 9-10 Silena quad bias supply (CD E detector bias)
- Slot 11-12 Sixfold preamp power supply for beam dump detector
- Slot 13-14 empty
- Slot 15-16 empty
- Slot 17-18 empty
- Slot 19-20 Ortec 480 pulser (CD pulser)
- Slot 23-24 ECL → NIM converter (particle trigger)

## 30.2 Rack 2

In rack 2 we have two crates for the RAL 109 modules with their power supplies and the new DAQ computer pcepuis16 with its RAID array. The NIM crate which was previously in the place now occupied by the DAQ computer is now in R1.C4.

### 30.2.1 KM-6 crate R2.C1

- Slot 1 - RAL 109 s/n 70 (annular strips)
- Slot 2 - RAL 109 s/n 71 (annular strips)
- Slot 3 - RAL 109 s/n 72 (annular strips)

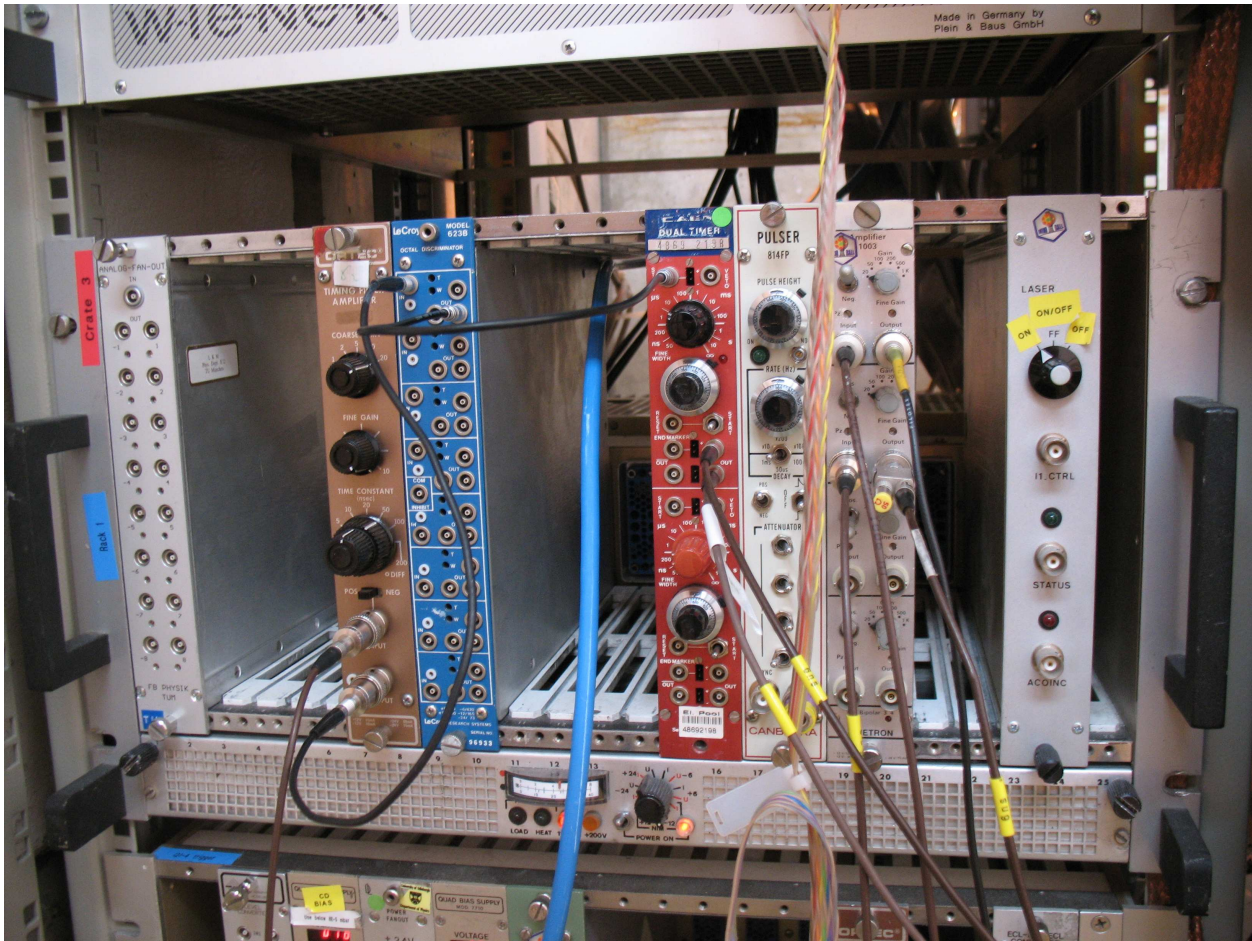

Figure 29: R1.C3: NIM crate - nothing here is used. At this time, the laser control unit was in this crate, but not in use.

- Slot 4 - RAL 109 s/n 73 (annular strips)
- Slot 5 - RAL 109 s/n 74 (annular strips)
- Slot 6 - RAL 109 s/n 75 (annular strips)
- Slot 7 - RAL 109 s/n 76 (annular strips)
- Slot 8 - RAL 109 s/n 77 (annular strips)
- Slot 10 - RAL 109 s/n 91 (PAD detector)

### 30.2.2 KM-6 crate R2.C2

- Slot 1 - RAL 109 s/n 78 (sector strips)
- Slot 2 - RAL 109 s/n 79 (sector strips)
- Slot 3 - RAL 109 s/n 80 (sector strips)
- Slot 4 - RAL 109 s/n 81 (sector strips)
- Slot 5 - RAL 109 s/n 82 (sector strips)
- Slot 6 - RAL 109 s/n 83 (sector strips)
- Slot 7 - RAL 109 s/n 84 (sector strips)
- Slot 8 - RAL 109 s/n 85 (sector strips)
- Slot 9 - RAL 109 s/n 86 (sector strips)
- Slot 10 - RAL 109 s/n 87 (sector strips)
- Slot 11 - RAL 109 s/n 88 (sector strips)



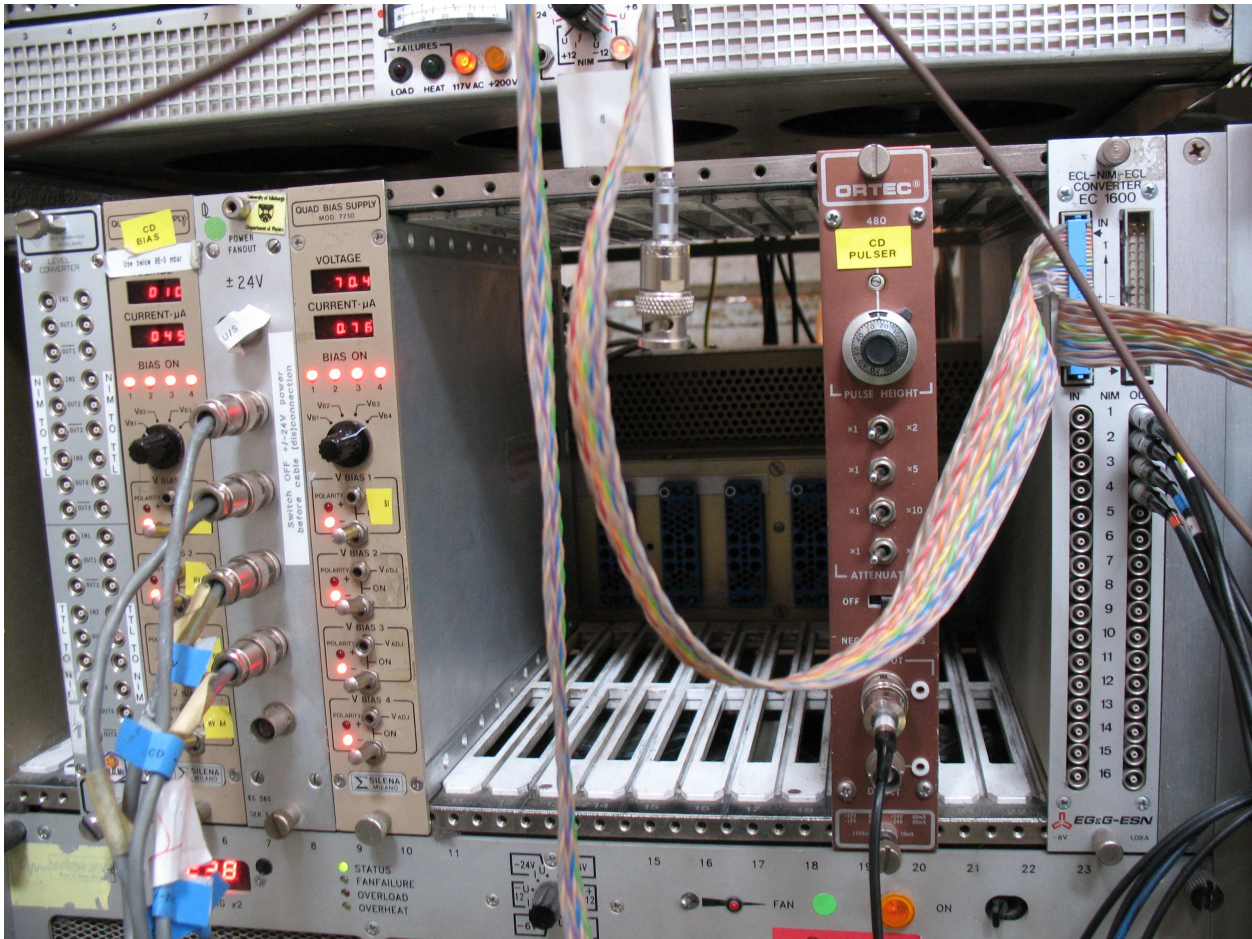

Figure 30: R1.C4: NIM crate - various modules for CD power etc.

- Slot 12 - RAL 109 s/n 89 (sector strips)
- Slot 15 - RAL 109 s/n 90 (unused)

### 30.2.3 New DAQ computer and raid array R2.C3

### 30.2.4 CD connectors and power supplies

At the back of rack 2 we have various connectors and power supplies for the CD detector.

## 30.3 Rack 3

In rack 3 we have a VME crate and three high-power NIM crates.

### 30.3.1 VME crate R3.C1

- Slot 1 - power PC
- Slot 2 - VME trigger module
- Slot 4 - Mesytech MADC32 (CD E Q1) 0xF10000
- Slot 5 - Mesytech MADC32 (CD E Q2) 0xF30000
- Slot 6 - Mesytech MADC32 (CD E Q3) 0xF40000
- Slot 7 - Mesytech MADC32 (CD E Q4) 0xF50000
- Slot 8 - CAEN V775 TDC (CD T Q1) 0xF70000
- Slot 9 - CAEN V775 TDC (CD T Q2) 0xF80000
- Slot 10 - CAEN V775 TDC (CD T Q3) 0xF90000



Figure 31: R2.C1: The RAL109s for the front rings. The upper connections are for the energy and they are joined up in pairs and sent to the ADC. The lower connections are for the timing and they go to the MALU in R1.C2 and from there to the TDCs in R3.C1.

- Slot 11 - CAEN V775 TDC (CD T Q4) 0xFA0000
- Slot 12 - Mesytech ADC (unused) 0xF60000
- Slot 13 - pattern unit 0x303800
- Slot 14 - scaler with NIM inputs 0x302800
- Slot 15 - scaler with ECL inputs (PPAC X) 0x300800
- Slot 16 - scaler with ECL inputs (PPAC Y) 0x301800
- Slot 17 - Wiener VC32 (CAMAC 1) 0x550000
- Slot 18 - Wiener VC32 (CAMAC 2) 0x558000
- Slot 19 - Wiener VC32 (CAMAC 3) 0x560000
- Slot 20 - SiS 3300 100 MHz 12 bit ADC (Bragg Detector) 0x40000000
- Slot 21 - VDIS

### 30.3.2 NIM crate R3.C2

- Slot 1-6 - TB8000 trigger box (triple width) “Trigger box”
- Slot 7-8 - CAEN N454 4x4 fan-in/fan-out “Delay trg Q1...4”
- Slot 9-10 - LeCroy 370C strobed coinc “coinc PG1...4”, “four channels unused”
- Slot 11-12 - CAEN N455 quad coinc logic “Q1...4 coinc or downscaled”
- Slot 13-14 - LeCroy 465 triple coinc unit “DGF Synch or ADC busy for Q1...3”

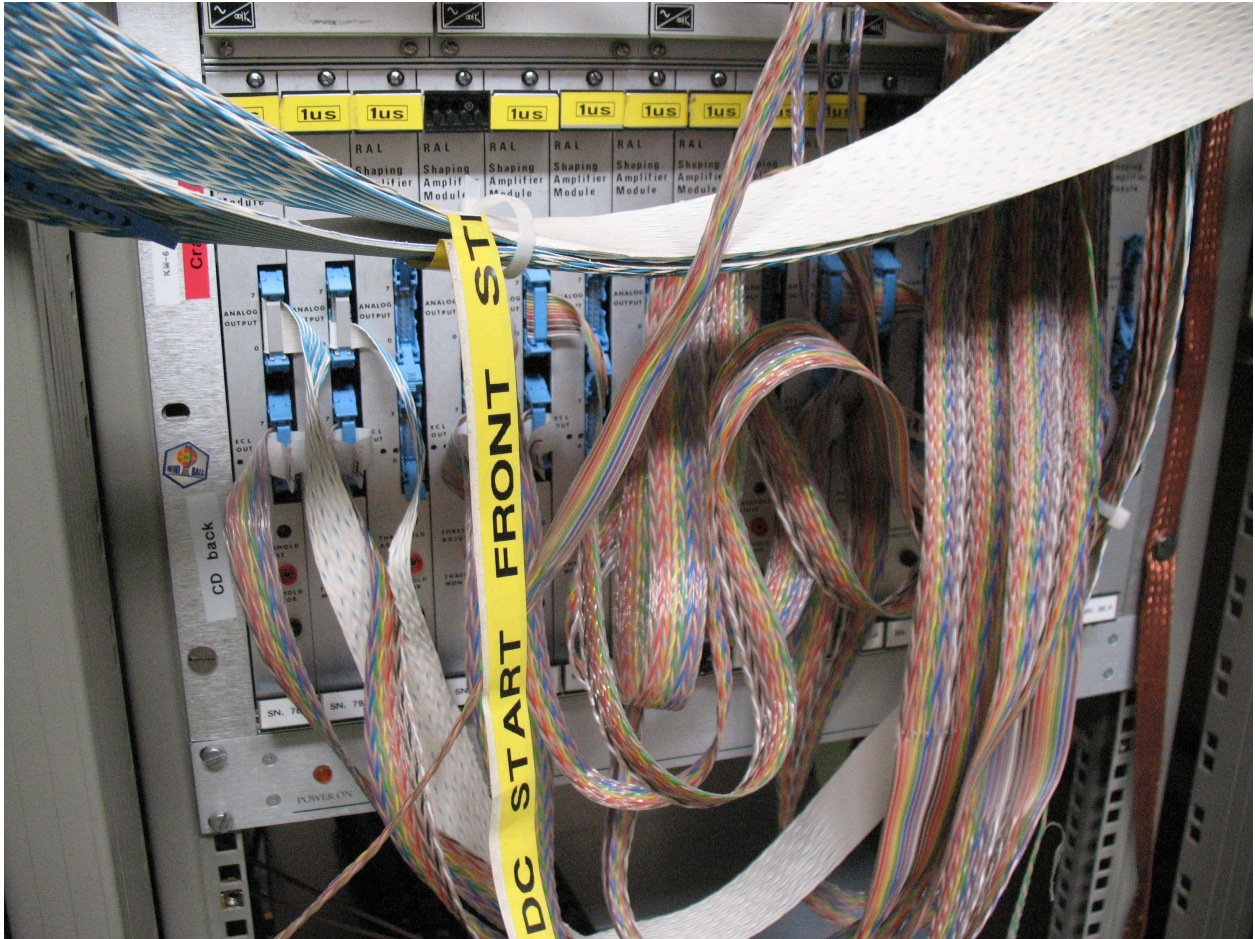

Figure 32: R2.C2: The RAL109s for the back sectors. The upper connections are for the energy and they are joined up in pairs and sent to the ADC. Note that the first pair has the blue and white cable on to which the signal for laser power is added. The lower connections are for the timing and they go directly to the TDC in R3.C1

- Slot 15-16 - LeCroy 465 triple coinc unit “DGF Synch or ADC busy for Q4”, “DAQ trig if DAQ not busy”, “unused”
- Slot 17-18 - GG8000 octal gate generator “Q1... 4 ADC/TDC gate”, “unused”, “Bad”, “DAQ trigger”, “ $\gamma$  OR”
- Slot 19-20 - LeCroy 429A 4x4 fan-in/fan-out “Q1... 4 ADC/TDC gate”
- Slot 21-22 - IKP modified TFA (in Ortec housing) “Mult out”
- Slot 23-24 - CAEN N454 2x8 fan-in/fan-out “Gamma Or”, “Si OR”

### 30.3.3 NIM crate R3.C3

- Slot 1-2 - TTL/NIM  $\rightarrow$  ECL converter (set to NIM) “DAQ Trigger”
- Slot 3-4 - ECL  $\rightarrow$  TTL/NIM converter (set to NIM) “ADC1 dead”, “ADC2 dead”, “ADC3 dead”, “ADC4 dead”, “DAQ dead”, “DAQ Go”
- Slot 5-6 - LeCroy 429A 4x4 fan-in/fan-out “ADC busy or SYNCH 1... 4”
- Slot 7-8 - Noname dual timer “Delay Q1 (both parts)”
- Slot 9-10 - CAEN N93B dual timer “Delay Q2 (both parts)”
- Slot 11-12 - Noname dual timer “Delay Q3 (both parts)”
- Slot 13-14 - CAEN N93B dual timer “Delay Q4 (both parts)”
- Slot 15-16 - LeCroy 429A 4x4 fan-in/fan-out “Q1... 4 trigger”
- Slot 17-18 - LeCroy 429 2x8 fan-in/fan-out “MADC clock”, “MADC reset”

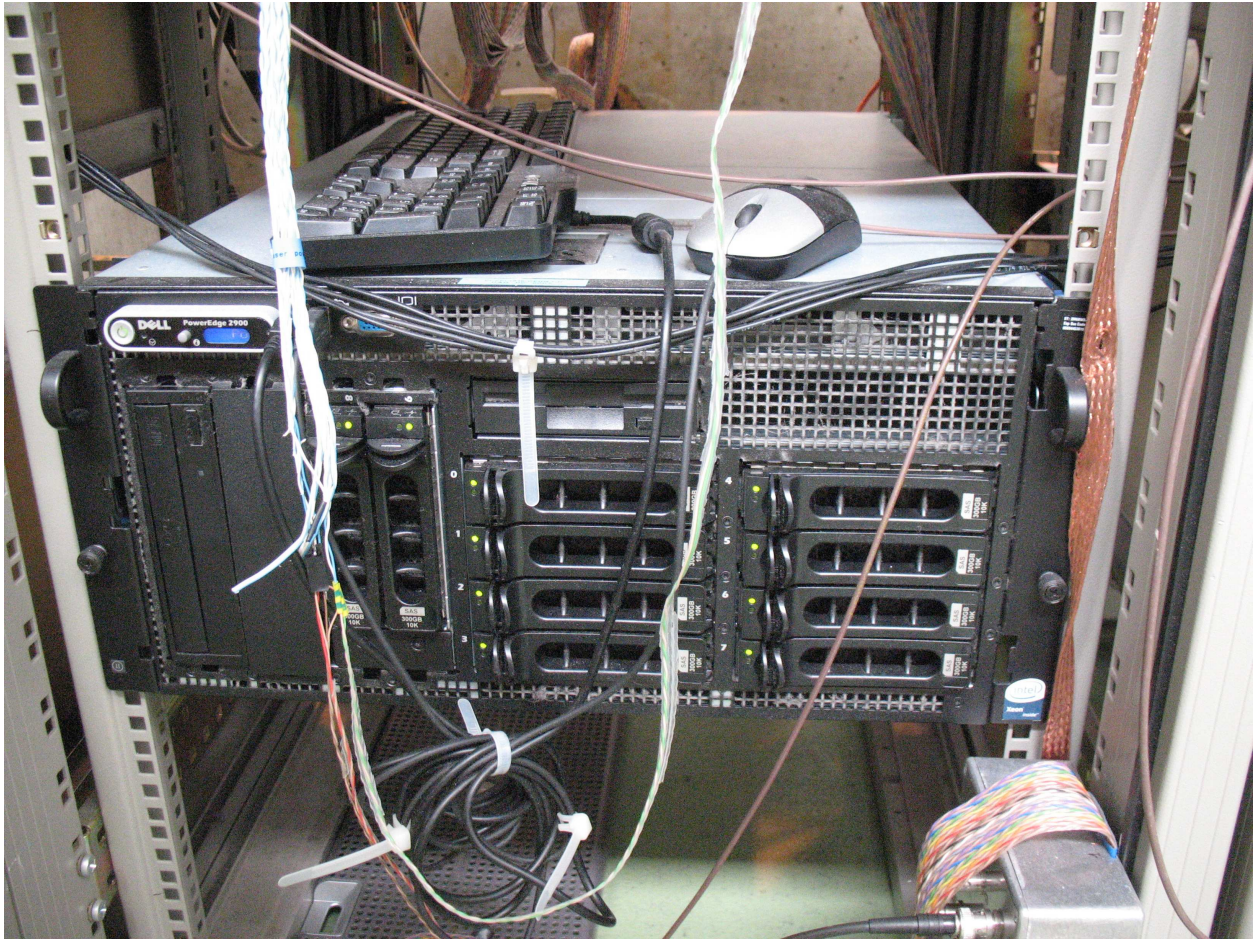

Figure 33: R2.C3: The new DAQ computer and raid array

- Slot 19-20 - LeCroy 465 triple coincidence unit “1 MHz and laser on”, “Ion and not DAQ dead”, “1s and EBIS”
- Slot 21-22 - CAEN 2255A Dual Timer “DAQ dead extend”, “1s in EBIS”
- Slot 23-24 - CAEN N454 4x4 fan-in/fan-out “DAQ dead”, “DAQ dead+”, “DAQ dead+”, “1s in EBIS”

### 30.3.4 NIM crate R3.C4

- Slot 1-2 - TTL → NIM and NIM → TTL converter “EBIS pulse”, “PS”, “T1”
- Slot 3-4 - ISOLDE 1Hz-1MHz clock
- Slot 5-6 - LeCroy 429A 4x4 fan-in/fan-out “Laser off”, “1 MHz”, “not used”, “not used”
- Slot 7-8 - CAEN N455 quad coinc logic “T1 AND DGF busy”, “1 MHz and on win”, “1 MHz and on/off”, “DGF busy and PS start”
- Slot 9-10 - Noname dual timer “Delayed TS PS start”, “PS del”
- Slot 11-12 - CAEN 2255B dual timer “unused”, “direct TS PS start”
- Slot 13-14 - CAEN 2255B dual timer “MADC reset”, “MADC reset width”
- Slot 15-16 - CAEN N454 4x4 fan-in/fan-out “T1”, “start PS cycle”, “DGF busy”, “10  $\mu$ s after DGF not busy”
- Slot 17-18 - CAEN N93B dual timer “T1 veto”, “TS delay”
- Slot 19-20 - CAEN 2255B dual timer “10  $\mu$ s del”, “something bizarre!”
- Slot 21-22 - Phillips quad linear fan-in/fan-out “unused”, “T1 not busy”, “PS TS”, “unused”
- Slot 23-24 - CAEN 2255B dual timer “TS gate T1”, “TS gate T1 delay”

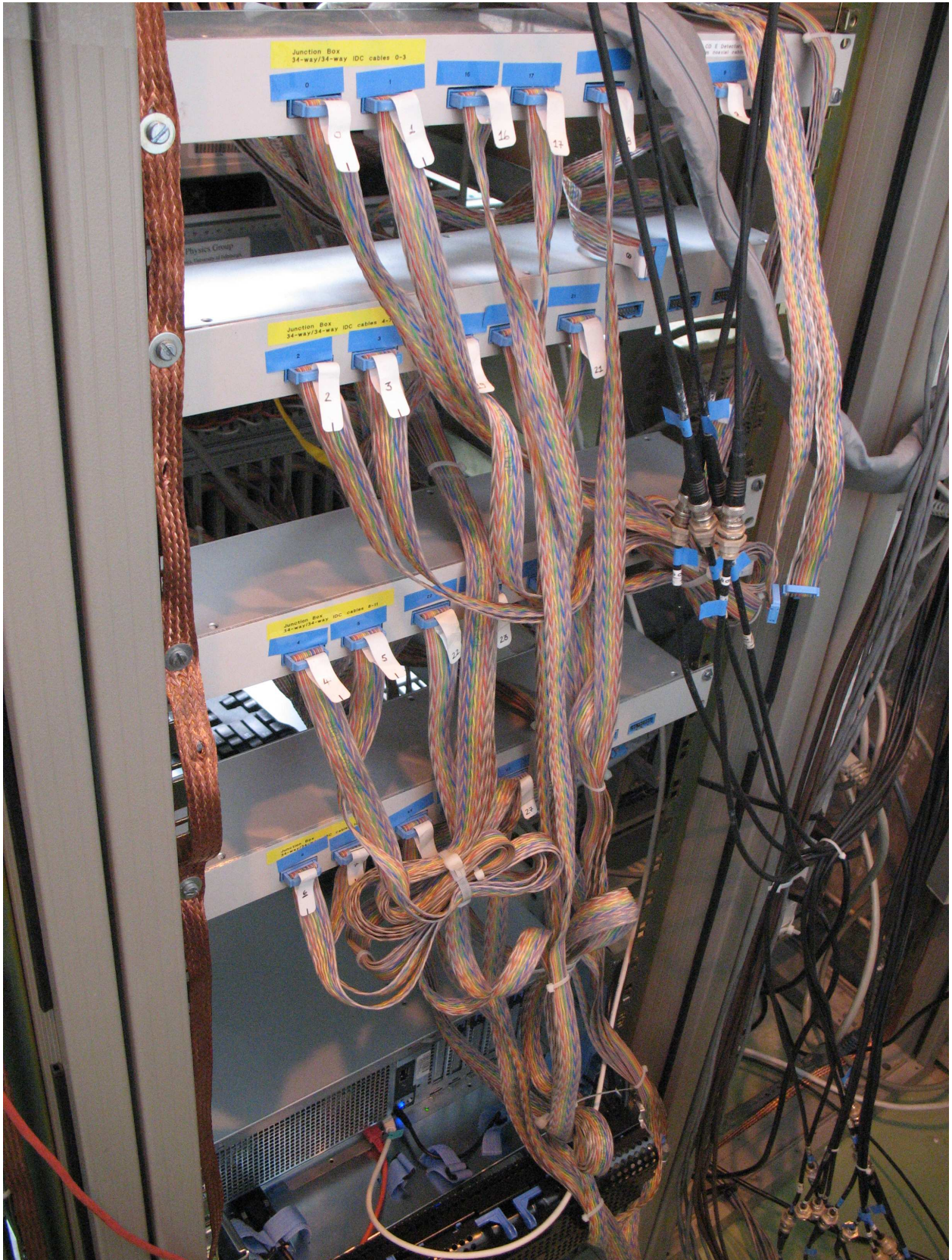

Figure 34: R2.rear: various CD connectors and power supplies

### 30.3.5 Preamp power - R3 rear

At the back of rack 3, we have the preamp power for the Miniball detectors and possibly PPAC and beam-dump detector preamp power. Note that this module only supplies  $\pm 12$  Volts. (Some detectors may require  $\pm 24$  Volts as well and cannot be used with this power supply).

This power supply is in two parts, the power supply itself (like that for a crate) and the distribution panel with a row of D-sub connectors.

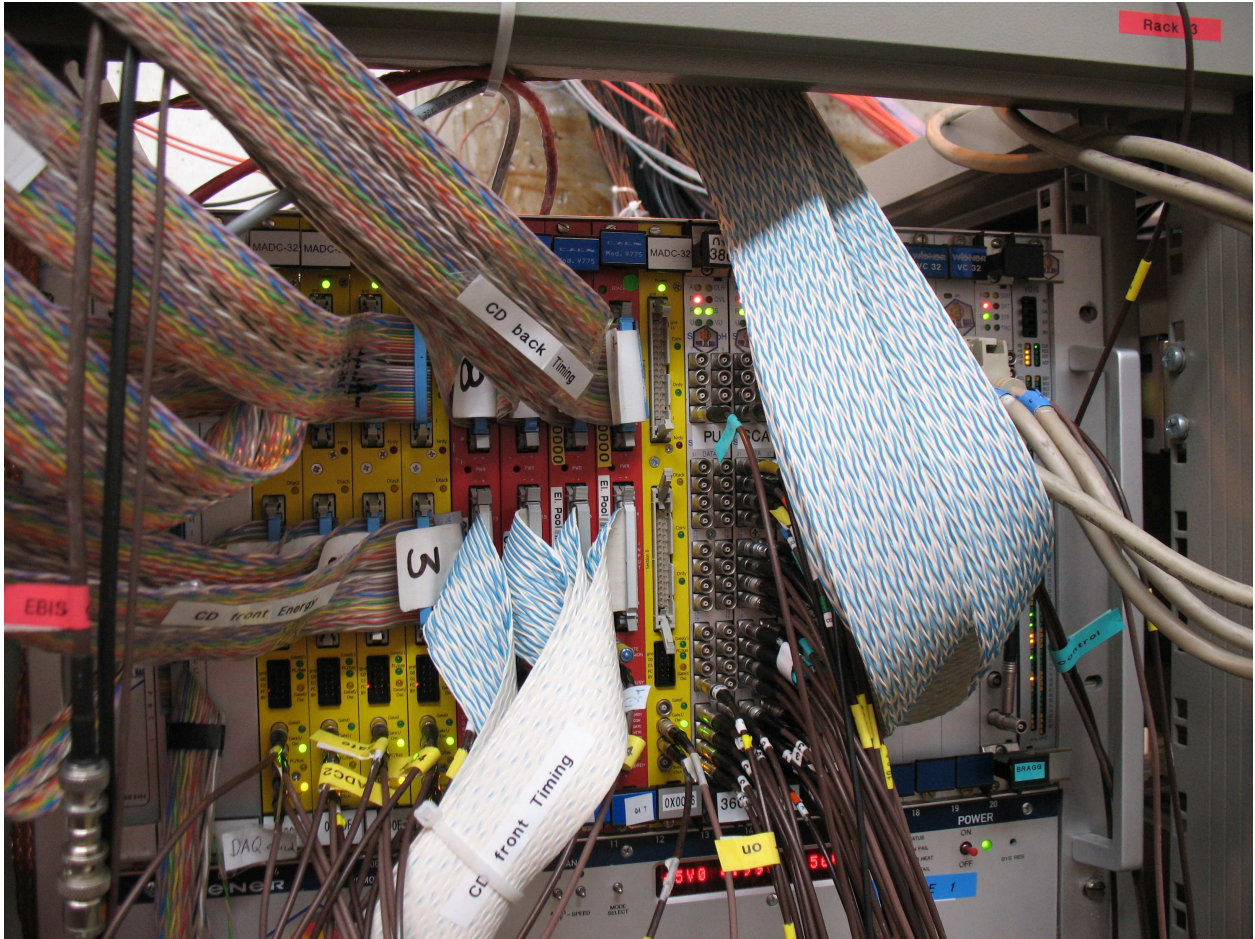

Figure 35: R3.C1: The cabling of the CD to the VME ADCs and TDCs. The four ADCs are the left red modules and the four TDCs are the next four. The front signals use the lower parts of the ADCs and TDCs and the back signals use the upper parts. Also shown is the bunch of LEMO cables for the scalars, the pair of blue and white flat cables for the PPAC and the SCSI cables for the VC32→CC32 connection

Note this preamp power supply should be connected to the mains via a dead-man's switch, which switches off if the mains power goes off. So if we have a power failure, the preamp power doesn't automatically come on, but has to be reset manually by pushing the button. The reason for this is that when the power comes back on at CERN after a power outage, there is a huge surge, as all the machines start up, which can damage the warm preamps.

## 30.4 Rack 4

In rack 4 we have three CAMAC crates and one high-power NIM crate.

### 30.4.1 CAMAC crate R4.C1

- Slot 3 - XIA DGF 1154
- Slot 4 - XIA DGF 1153
- Slot 5 - XIA DGF 1119
- Slot 6 - XIA DGF 1103
- Slot 7 - XIA DGF 1101
- Slot 8 - XIA DGF 1148
- Slot 9 - IKP 40 MHz clock
- Slot 10 - XIA DGF 1158
- Slot 11 - XIA DGF 1107
- Slot 12 - XIA DGF 1163

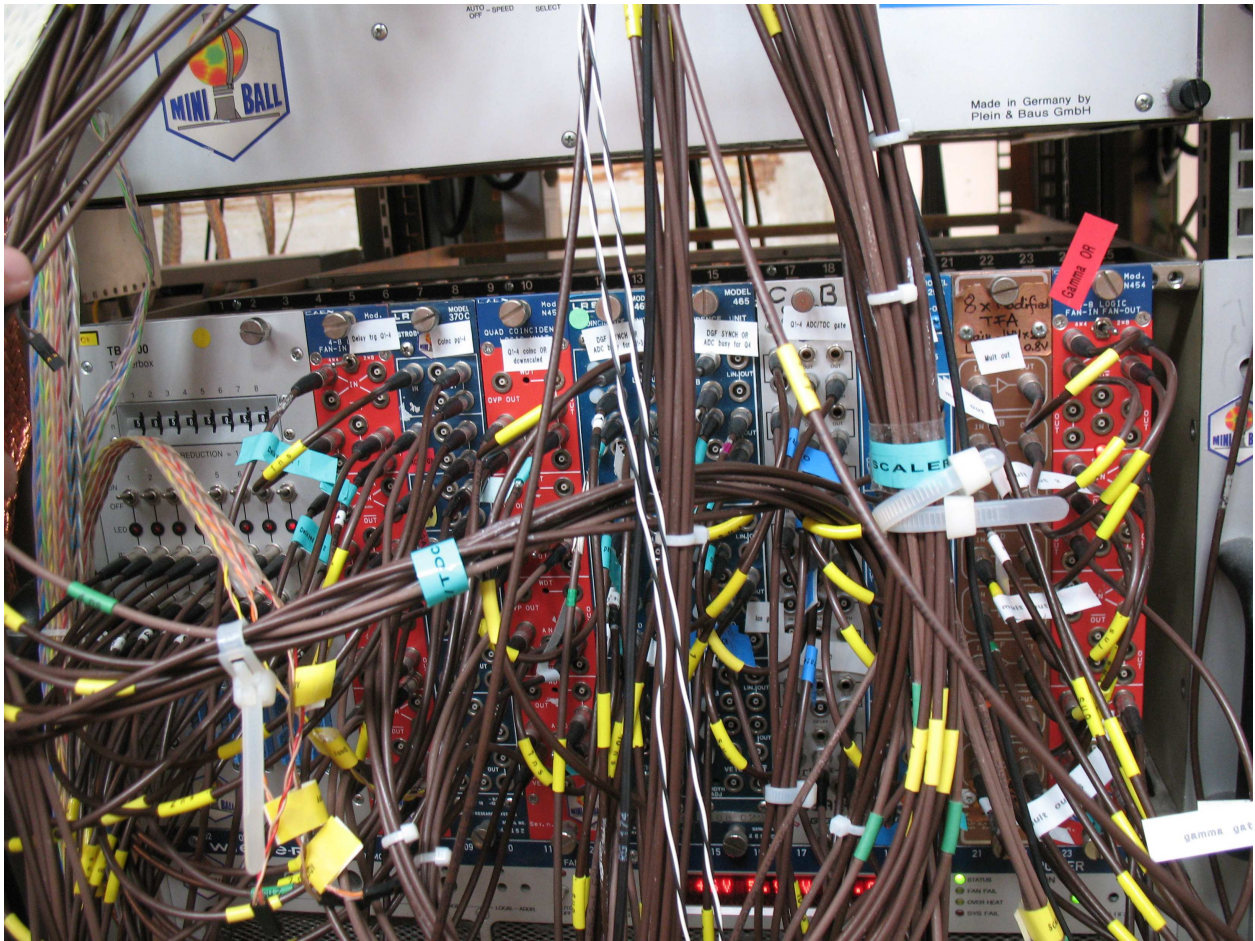

Figure 36: R3.C2: NIM crate - mostly trigger logic

- Slot 13 - XIA DGF 1139
- Slot 14 - XIA DGF 1162
- Slot 15 - XIA DGF 1161
- Slot 16 - XIA DGF 1120
- Slot 17 - XIA DGF 1166
- Slot 18 - XIA DGF 1194
- Slot 19 - XIA DGF 1184
- Slot 20 - XIA DGF 1122
- Slot 21 - XIA DGF 1174
- Slot 24-25 Wiener CC32

#### 30.4.2 CAMAC crate R4.C2

- Slot 3 - XIA DGF 1176
- Slot 4 - XIA DGF 1175
- Slot 5 - XIA DGF 1159
- Slot 6 - XIA DGF 1171
- Slot 7 - XIA DGF 1106
- Slot 8 - XIA DGF 1100
- Slot 9 - IKP 40 MHz clock

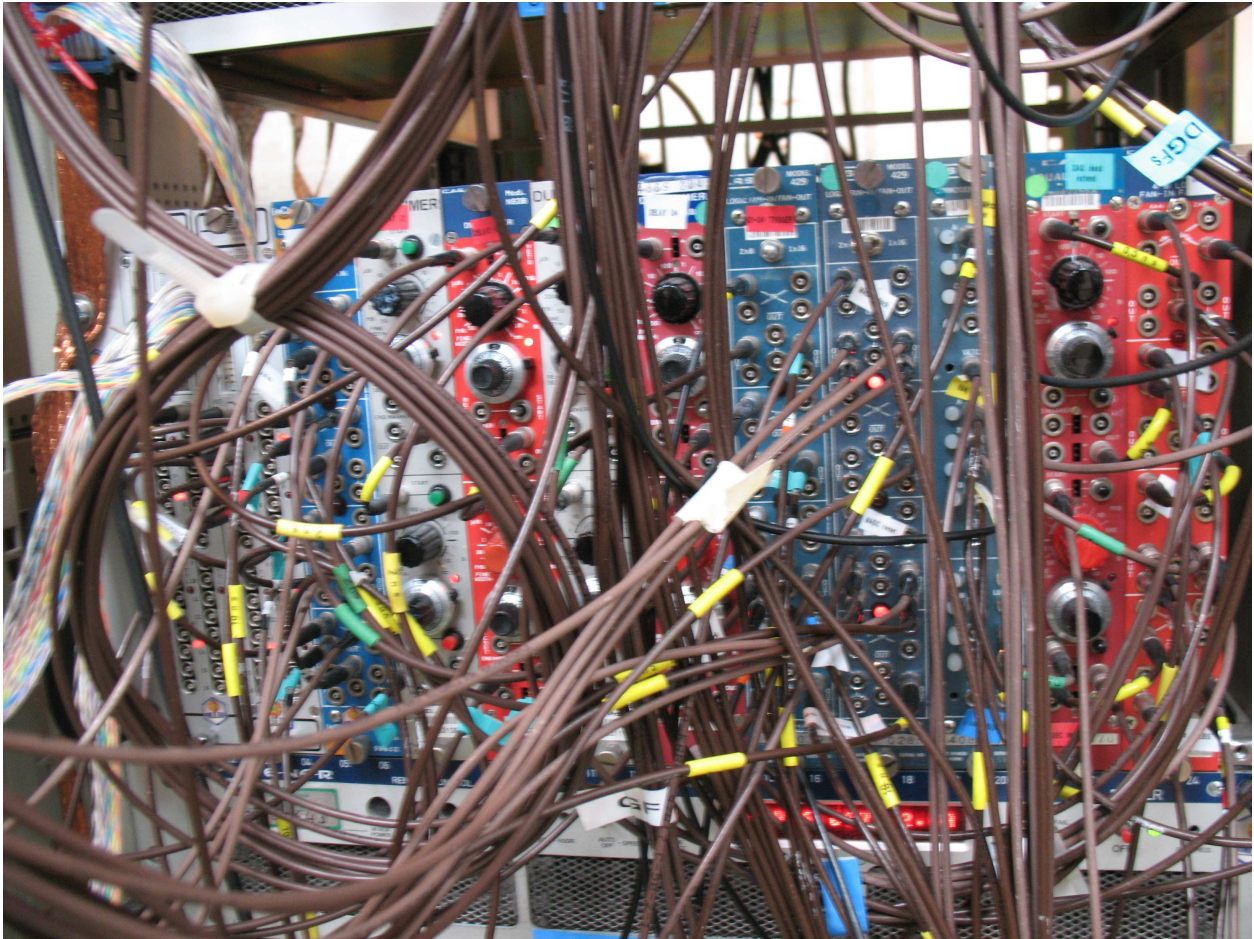

Figure 37: R3.C3: NIM crate - mostly trigger logic

- Slot 10 - XIA DGF 1108
- Slot 11 - XIA DGF 1190
- Slot 12 - XIA DGF 1152
- Slot 13 - XIA DGF 1167
- Slot 14 - XIA DGF 1113
- Slot 15 - XIA DGF 1104
- Slot 16 - XIA DGF 1130
- Slot 17 - XIA DGF 1123
- Slot 18 - XIA DGF 1192
- Slot 19 - XIA DGF 1138
- Slot 20 - XIA DGF 1128
- Slot 21 - XIA DGF 1147
- Slot 24-25 Wiener CC32

#### 30.4.3 R4.C3

- Slot 4 - XIA DGF 1132 "Q1 timestamp"
- Slot 5 - XIA DGF 1178 "Q2 timestamp"
- Slot 6 - XIA DGF 1149 "Q3 timestamp"
- Slot 7 - XIA DGF 1137 "Q4 timestamp"



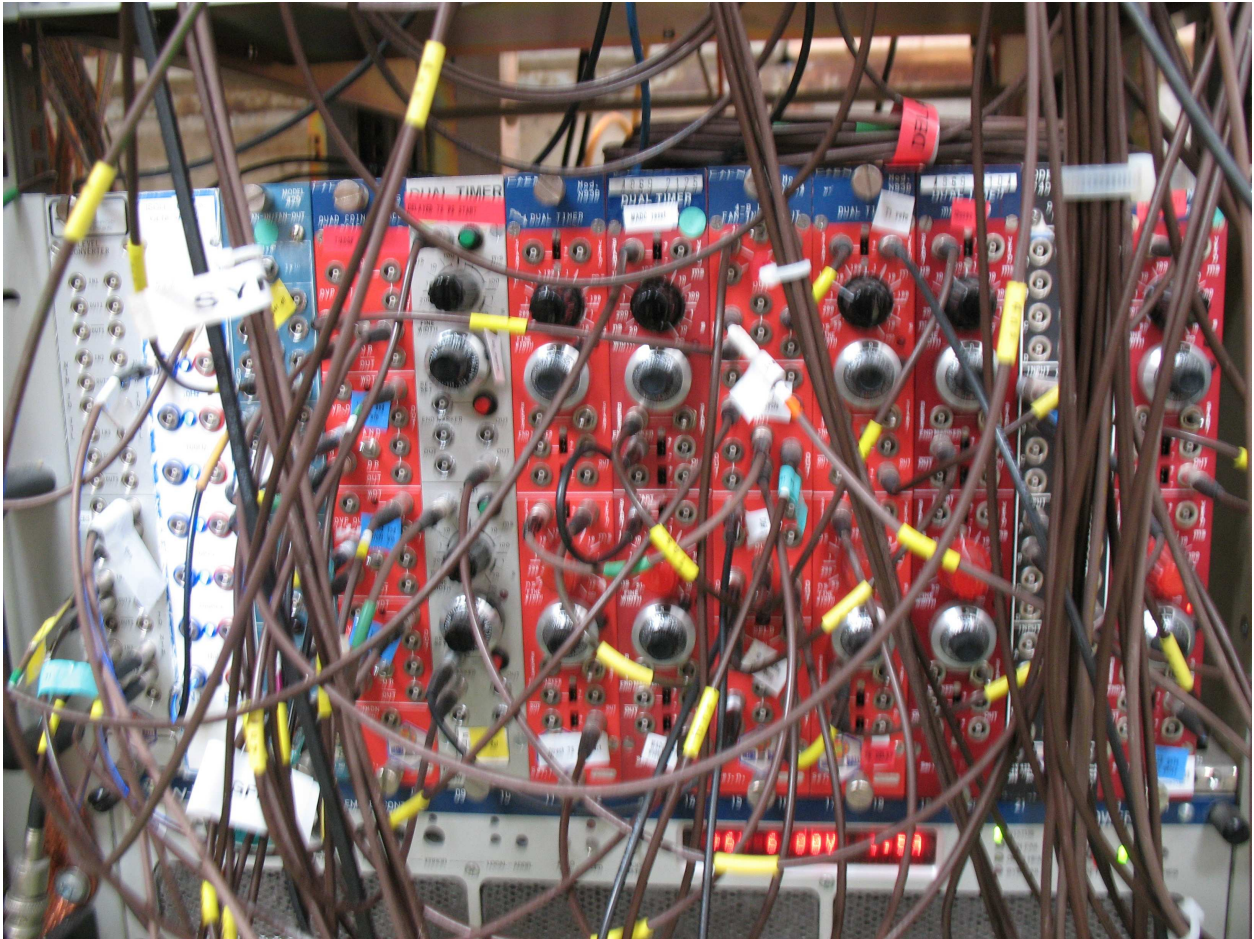

Figure 38: R3.C4: NIM crate - mostly PS and T1 signals. Note that in the photo, a spectroscopic amplifier is in slot 3-4 in place of the clock module.

- Slot 8 - XIA DGF 1142 “EBIS”, “T1”, ”PS”
- Slot 9 - XIA DGF 1189 “Beam dump”, “unused”, “unused”
- Slot 10 - IKP 40 MHz clock
- Slot 11 - XIA DGF 1124
- Slot 12 - XIA DGF 1170
- Slot 13 - XIA DGF 1129
- Slot 14 - XIA DGF 1169
- Slot 15 - XIA DGF 1151
- Slot 16 - XIA DGF 1150
- Slot 17 - XIA DGF 1145
- Slot 18 - XIA DGF 1118
- Slot 19 - XIA DGF 1134
- Slot 20 - XIA DGF 1193
- Slot 21 - XIA DGF 1186
- Slot 22 - XIA DGF 1109
- Slot 24-25 Wiener CC32

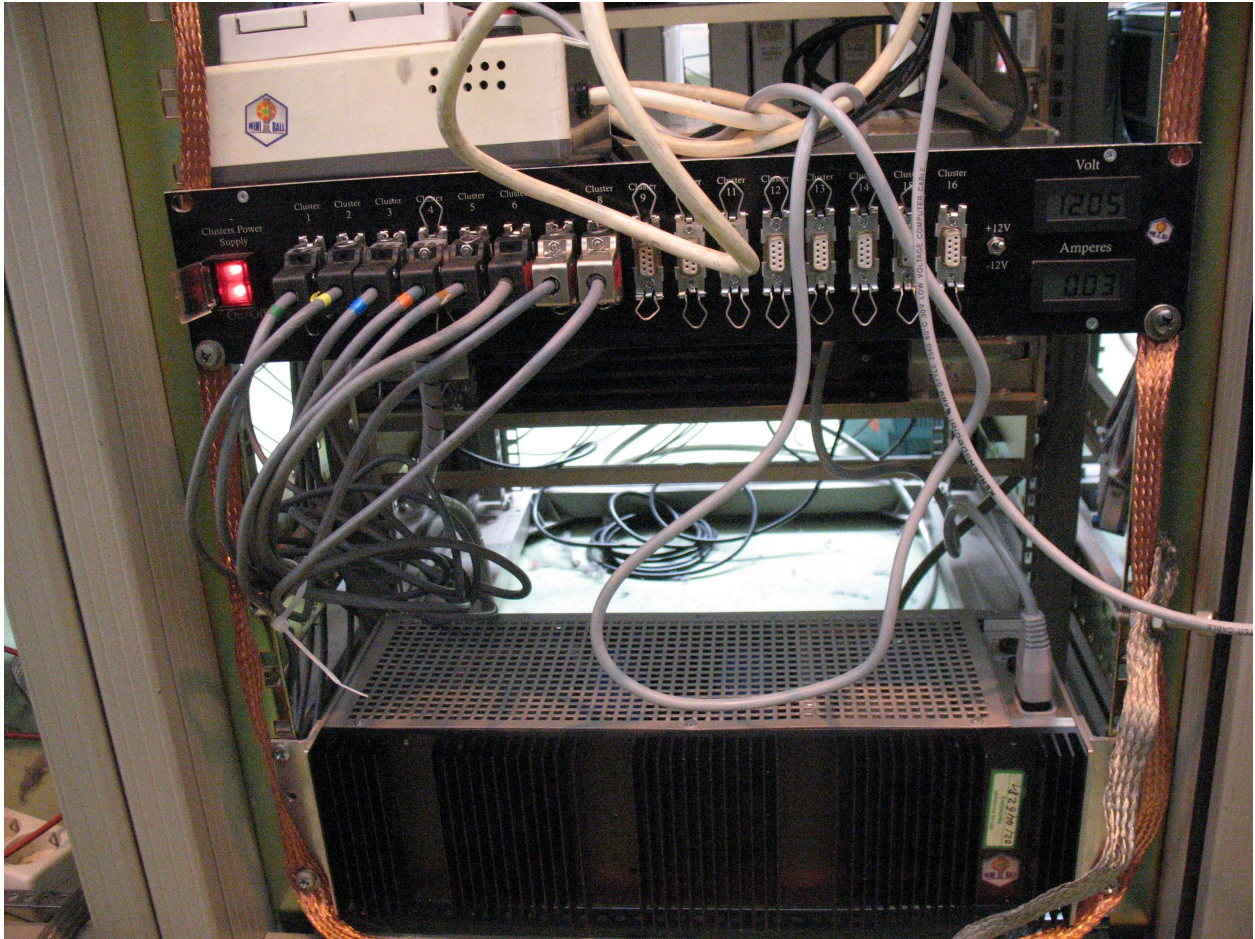

Figure 39: R3.rear: Preamp power supply and distributor

#### 30.4.4 NIM crate R4.C4

- 1-2 - CAEN N93B dual timer “Force readout”, “DAQ trigger”
- 3-4 - CAEN N93B dual timer “EBIS”, “Max on/off window”
- 5-6 - CAEN N454 4x4 fan-in/fan-out “EBIS pulse”, “EBIS pulse”, “GFLT”, “not used”
- 7-8 - LeCroy 365AL 4-fold logic unit “DAQ crash reset”, “End RDO and in time”
- 9-10 - CAEN N93B dual timer “TDGF Ebis”, “Off window”
- 11-12 - CAEN 2255B dual timer “Not busy”, “End RDO”
- 13-14 - IKP 3 fan-in/39 fan-out “GFLT”
- 15-16 - IKP 3 fan-in/39 fan-out “GFLT”
- 17-18 - IKP 3 fan-in/39 fan-out “Synch”
- 19-20 - IKP 3 fan-in/39 fan-out “Synch”
- 21-22 - IKP 39 fan-in/3 fan-out “Busy”
- 23-24 - IKP 39 fan-in/3 fan-out “Busy”

### 30.5 Rack 5

Rack five contains (from top to bottom) the old PT100 box, the filling computer monitor, the old filling computer (pcepssc22), its keyboard, the PT100 box, the four manifold controller boxes (with box D highest), raid array, old DAQ computer (pcepuis20), CAEN HV power supply and UPS.

Note that there are now two filling systems. The old filling computer (pcepssc22) is connected to the old PT100 readout and can be connected to the manifolds in place of the new system. In the photograph, the new system is connected (i.e. the PT100s from the detectors go to the new PT100 box and the manifolds

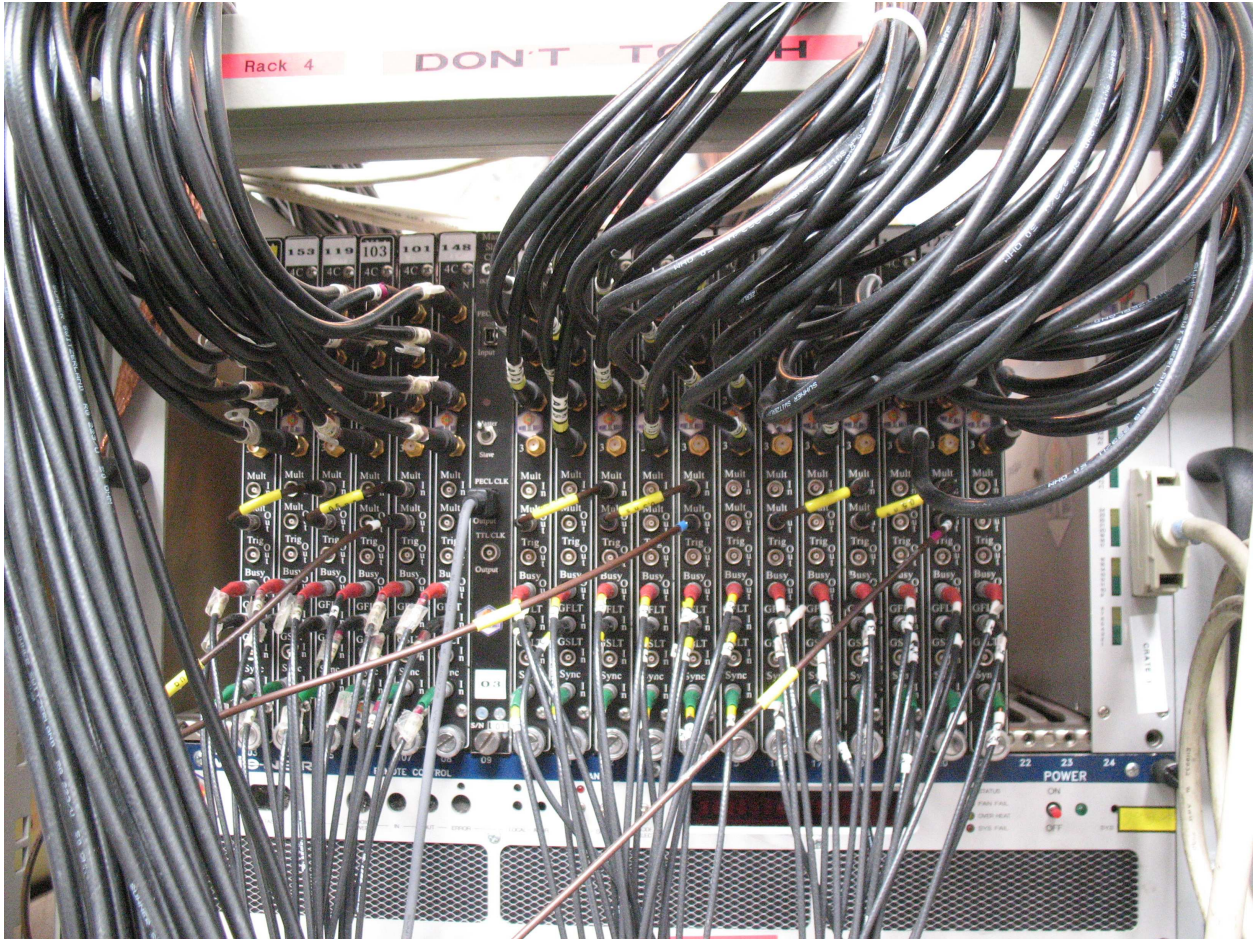

Figure 40: R4.C1: CAMAC crate of DGFs for three clusters.

are controlled by the new USB based system. The old DAQ computer (pcepis20) is being used as the filling computer. It is connected to the USB digital I/O for manifold control and the new PT100 readout via a USB hub.

### 30.5.1 Autofill connections - R5 rear

### 30.5.2 HV connections - R5 rear

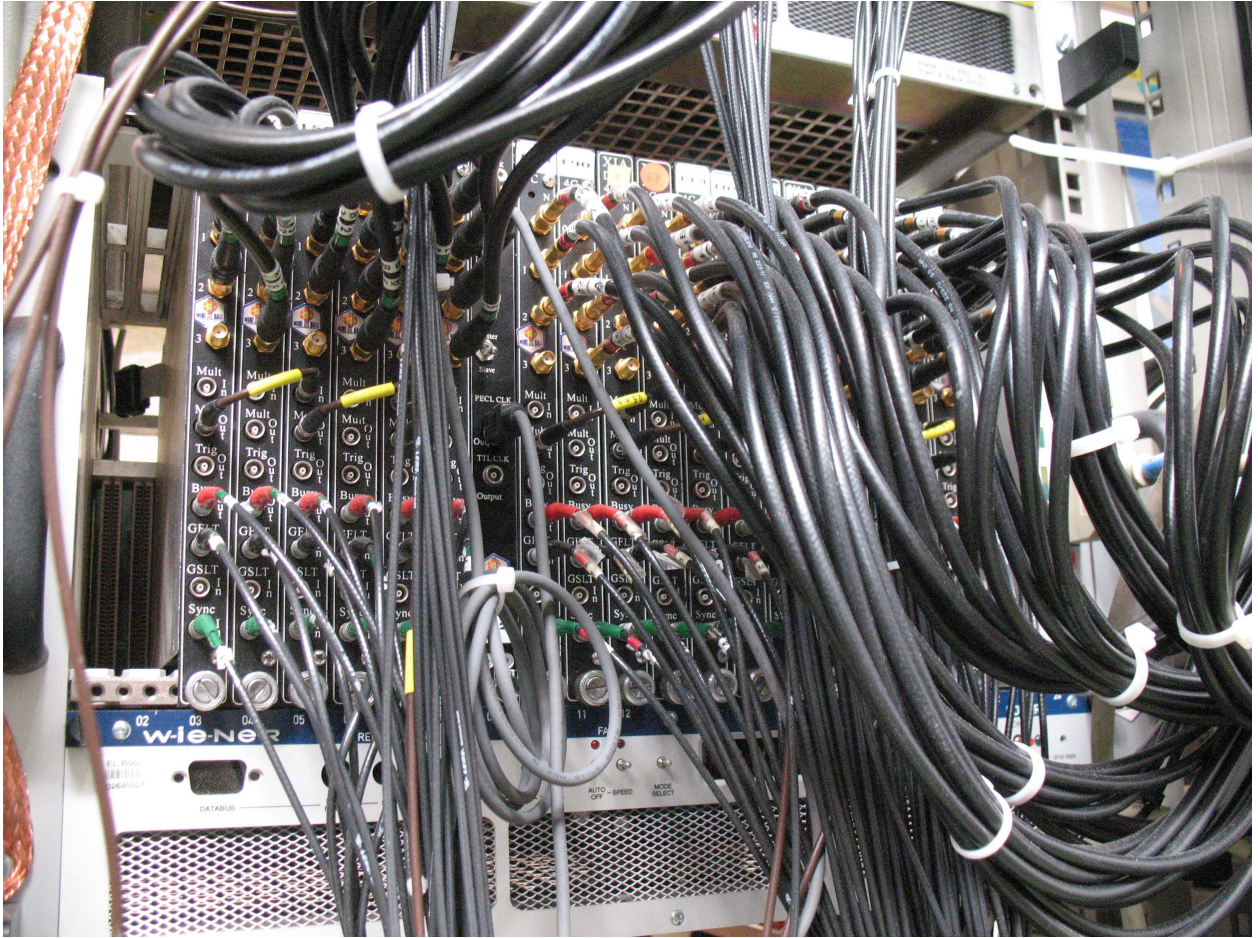

Figure 41: R4.C2: CAMAC crate of DGFs for three clusters.

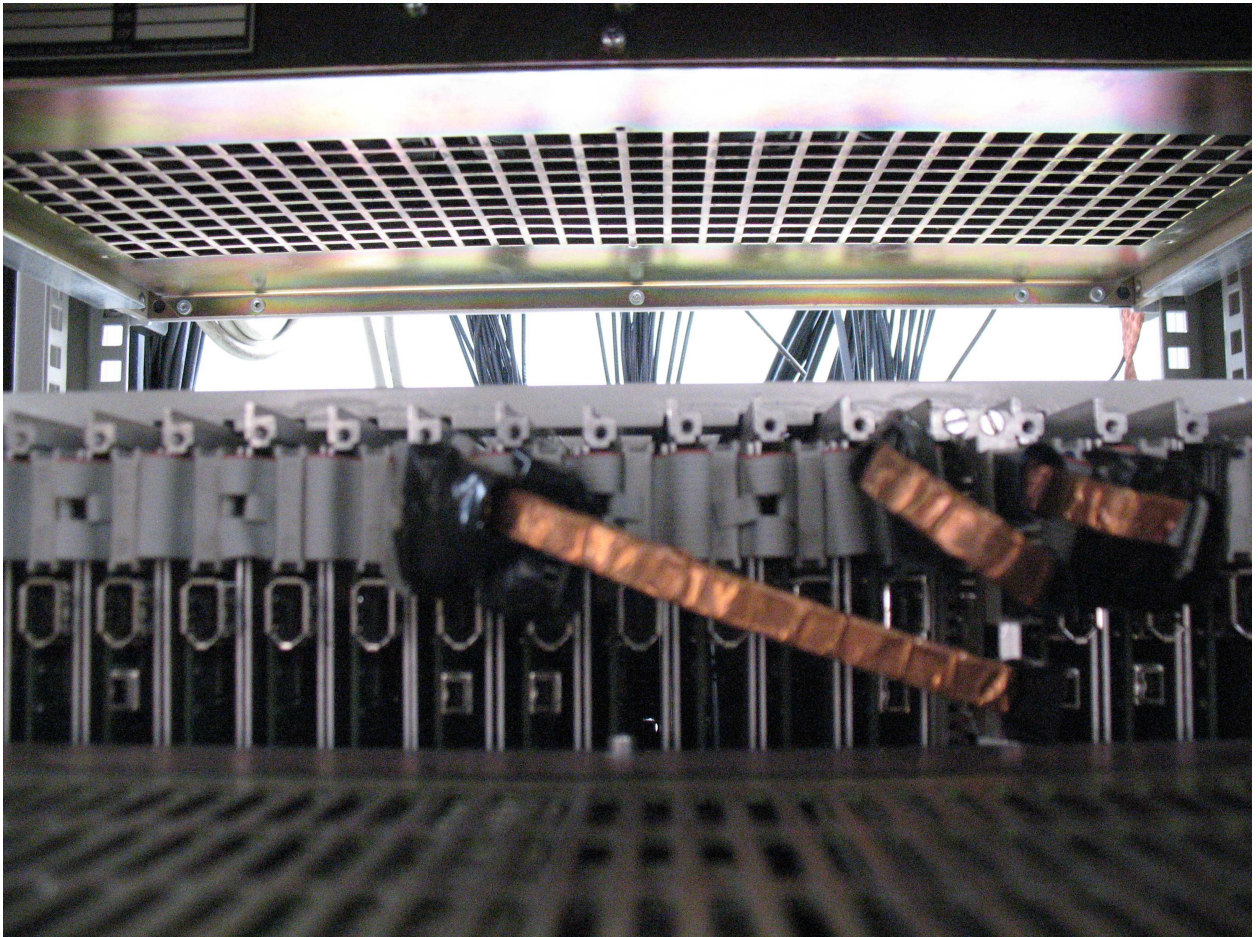

Figure 42: R4.C2: The rear of the DGFs showing the backplane bus connection. Each flat cable with 8 connectors has a terminator resistor block, six DGFs and the connector to the 40 MHz clock module. The trigger lines between DGFs associated with different capsules are cut, while those for each pair of DGFs handling a single capsule are connected.

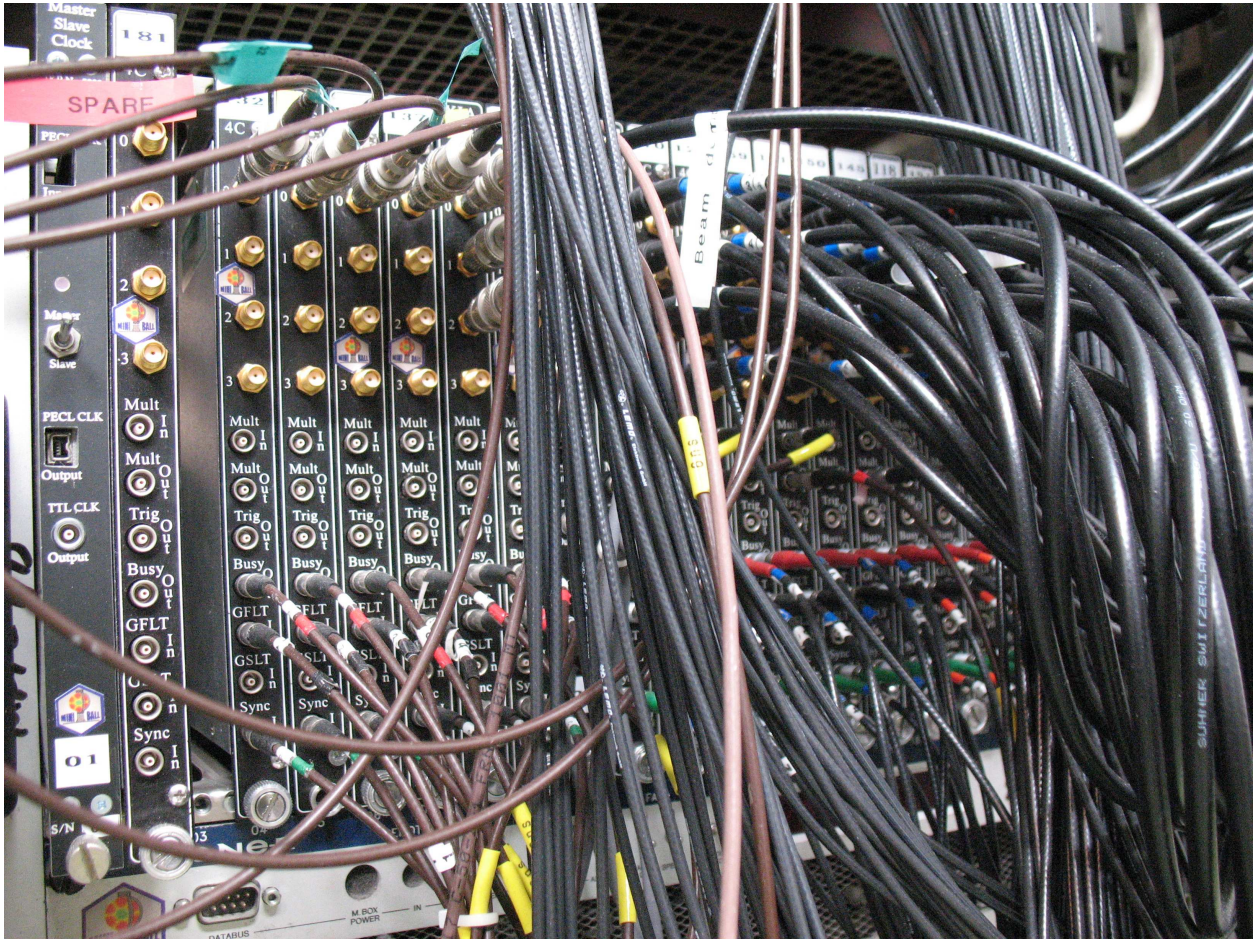

Figure 43: R4.C3: CAMAC crate of DGFs. Note the left four are the timestamper DGFs, then there is the EBIS etc. DGF and the sixth DGF is for the beam dump detector.

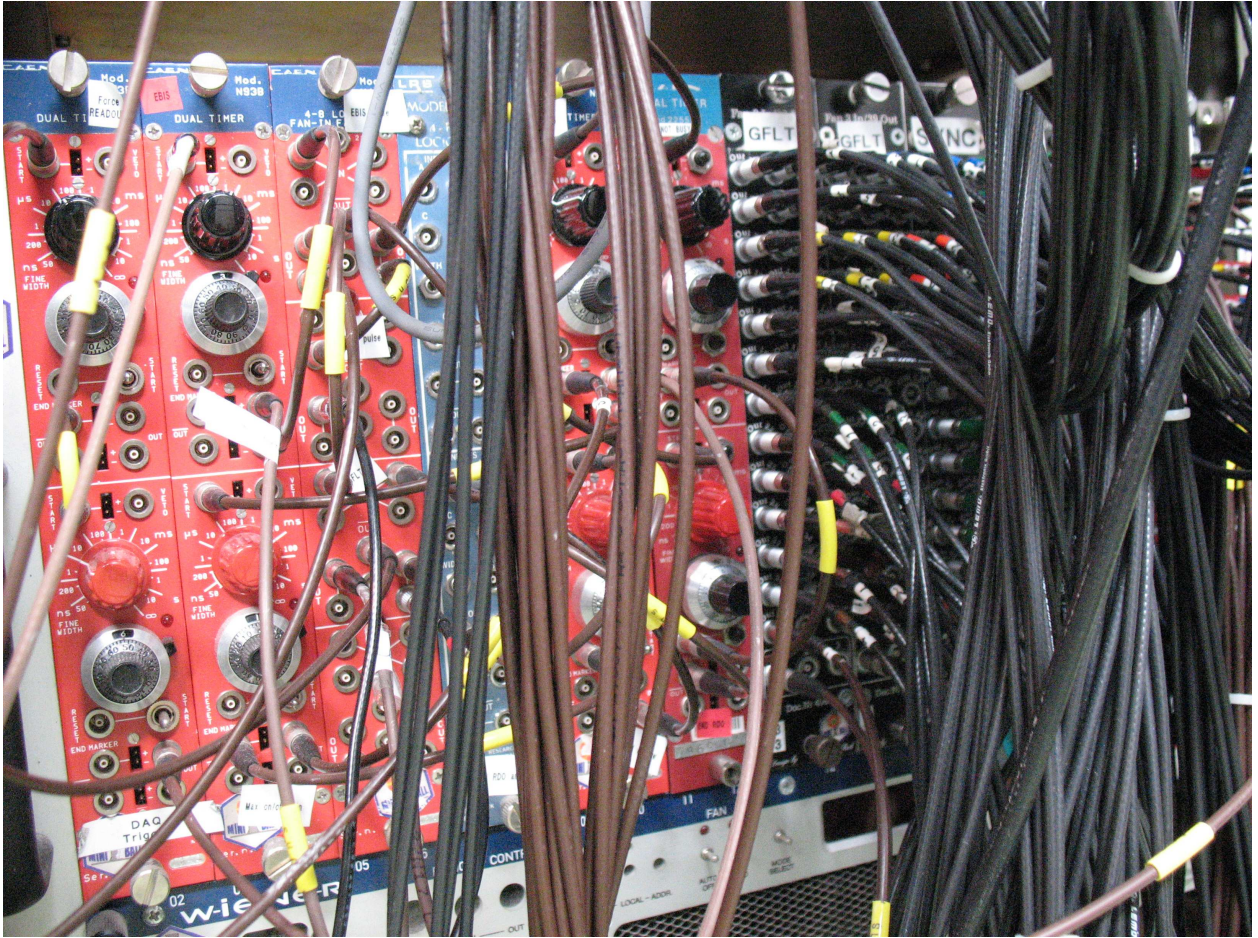

Figure 44: R4.C4: NIM crate



Figure 45: R5 bottom: filling system computer with monitor and keyboard, new PT100 box and four manifold controller boxes, raid array, DAQ computer, CAEN HV power supply and UPS. The old PT100 box is above the monitor.



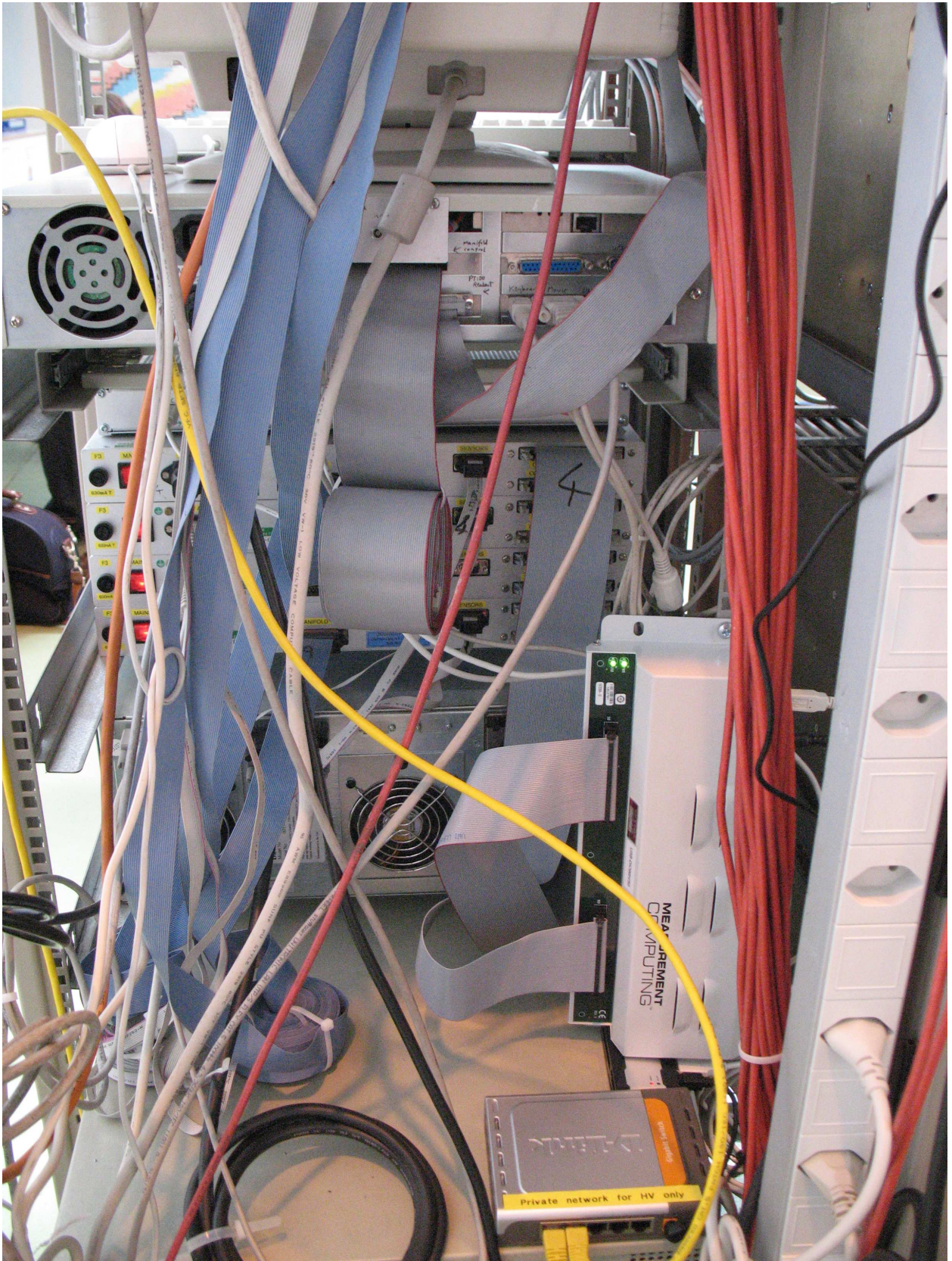

Figure 46: R5 rear: autofill connectors

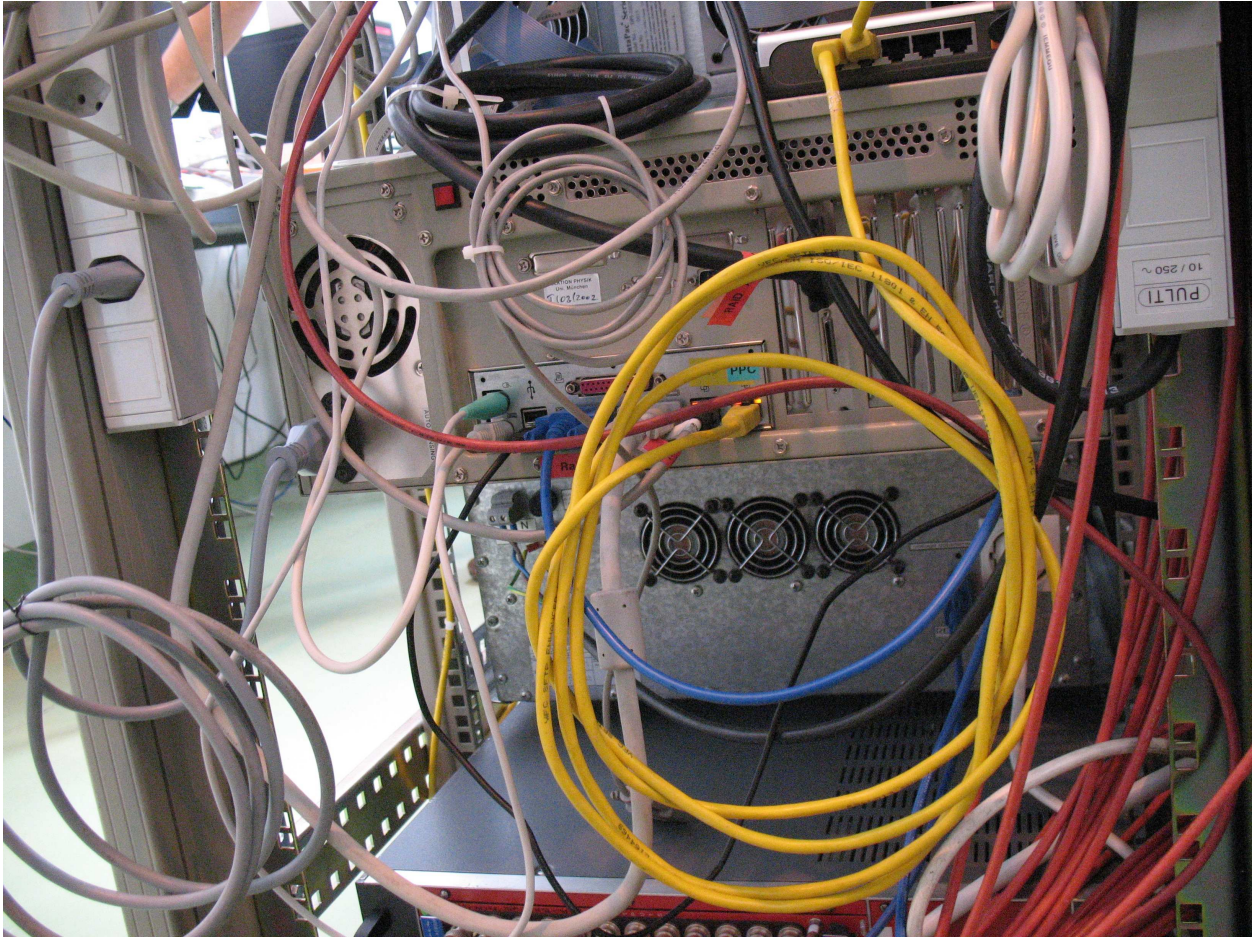

Figure 47: R5 rear: autofill connectors

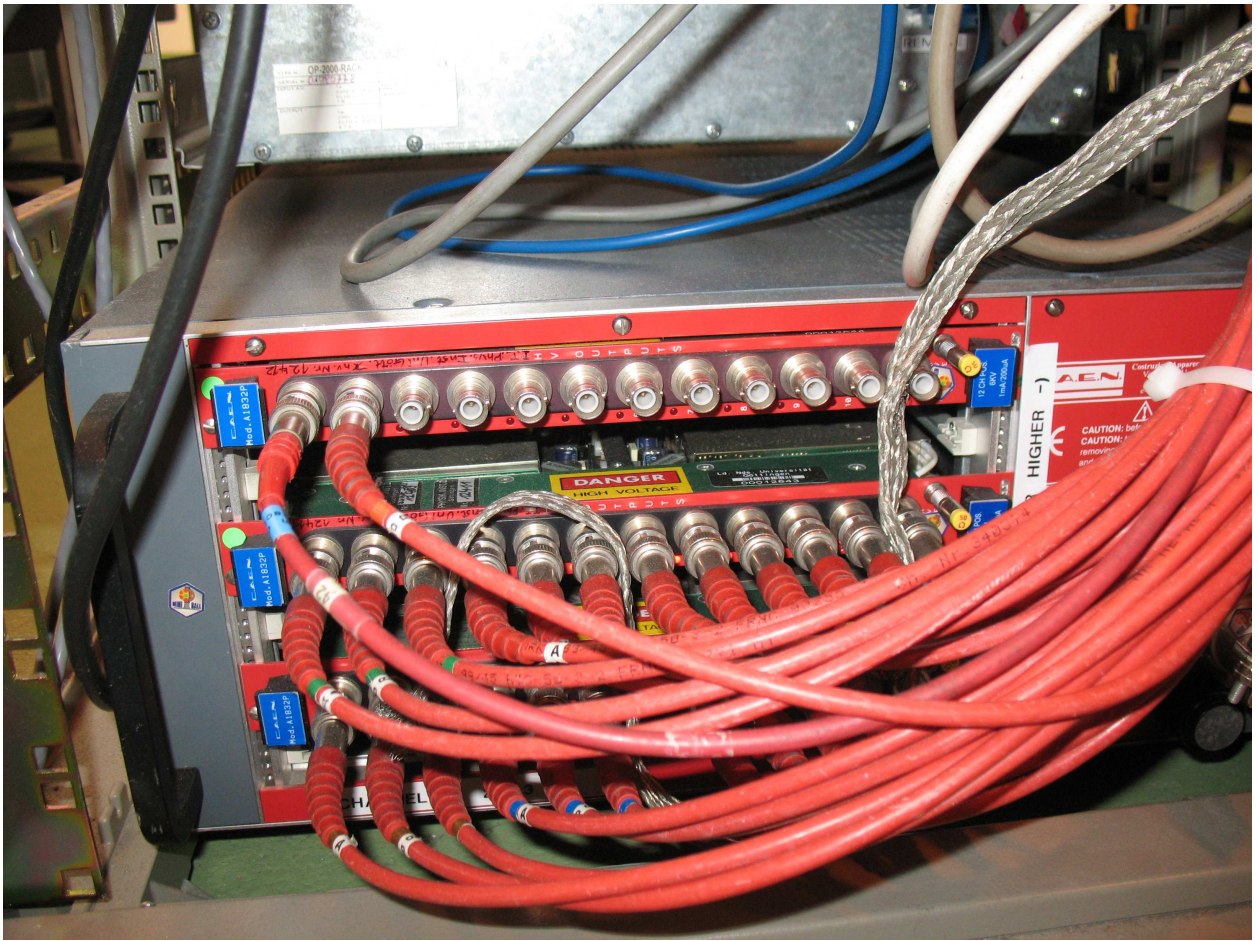

Figure 48: R5 rear: HV connectors